



1/26/21

Alaska Department of Environmental Conservation (ADEC)

RE: Alaska Regulation 18 AAC 50.077(c)
Report Revision Hearth & Home Technologies model PP70.

To Whom it May Concern:

This cover letter provides an overview of results generated from ADEC's review of OMNI certification report 0135PS104E generated for Hearth & Home Technologies. Stove model PP70 was tested in March 2018 to test standard ASTM 2779, and ASTM 2515. In 2020, ADEC reviewed a Non-CBI version of the report and released a list of findings from their report review. The following is a list of responses to the ADEC audit in the order they appeared in the Summary of Review.

1. Testing Information

- a.) *Third-party certifier not reported.* - Appliance is certified by OMNI-Test Laboratories as indicated by the signed certification test report and certificate of conformity.
- b.) *Report certified, not reported* - Appliance is certified by OMNI-Test Laboratories as indicated by the signed certification test report and certificate of conformity.

2. Test Report Elements

- a.) *Pre-burn completed by not reported* – Preburn (conditioning data) is shown on page 17 in the certification report, data was generated by Hearth & home representatives.
- b.) *Doc. Of run appropriateness not reported.* – Information was added to page 6 of the modified report covering appropriateness of the test run.
- c.) *Doc. Of run validity not reported* - Information was added to page 6 of the modified report covering validity of the test run.
- d.) *Doc. Of run anomalies not reported* - Information was added to page 6 of the modified report covering anomalies of the test run.



OMNI-Test Laboratories, Inc.

Product Testing & Certification

www.omni-test.com

Mailing: Post Office Box 301367 • 97294
Street: 13327 NE Airport Way • 97230
Portland, Oregon • USA

Phone: (503) 643-3788
Fax: (503) 643-3799
Email: contact@omni-test.com



3. Test Run Data

- a.) *Train precision % not reported* - Actual train precision % was not reported, quality checks do show Dual Train Comparison results are Acceptable on Emissions results page for each test run. Precision percentage and gram per kilogram comparison have been added to revised report page 22. Passing criteria is precision within 7.5% or gram per kilogram within 0.5.
- b.) *Negative weights handled appropriately* - On clean burning wood fired devices it is typical to capture near zero measurable catch. A built-in variance in the test standard for filters is 0.2 mg, meaning they are considered at a constant weight when weighed twice and show no more than ± 0.2 mg. Negative values of 0.2 mg should be allowed as part of the built-in variance. In some tests negative filter weights more than 0.2 mg are found, the corresponding weight can be seen on the O-ring or probe assembly final weights indicating transfer of material. There is no indication of total loss. Transfer of filter material to a secondary container using a solvent would only add additional error by 0.2 mg. for any weighing container, and possible errors in calculating residue weight of the solvent used. No changes were made to the report on this issue.

4. Owner's Manual Req.

- a.) *Improper fuel's warnings not included* – Owner's manual Pg13 "We recommend the use of Pellet Fuels Institute certified pellet fuel with this product". Owner's manual Pg22 provides information on how poor-quality fuels can affect appliance function.

5. Reporting

- a.) *Test report complete* - Requested information is explained above.
- b.) *Owner's manual complete* - Requested information is explained above.
- c.) *30-day notice submitted* - This information is not included in any certification reports, can be provided separately upon request.
- d.) *Testing on proposed dates* - This information is not included in any certification report, can be provided separately upon request.
- e.) *60-day report to EPA* - This information is not included in any certification reports, can be provided separately upon request.

Findings of this evaluation by ADEC did not produce any deficiencies that caused the Certified emissions and efficiency values for the Hearth & Home Technologies model PP70 to change. All requested changes are to simply clarify information already included in the certification report.

If you have any questions, please do not hesitate to contact **OMNI**.

Sincerely,

A handwritten signature in black ink, appearing to read "Bruce Davis".

Bruce Davis
Testing Manager

Non-Confidential Business Information (Non-CBI)

Certification Test Report

**Hearth and Home Technologies
Pellet-Fired Free Standing Room Heater
Model: PP70**

Prepared for: Hearth and Home Technologies
352 Mountain House Road
Halifax, PA 17032

Prepared by: OMNI-Test Laboratories, Inc.
13327 NE Airport Way
Portland, OR 97230
(503) 643-3788

Test Period: March 28, 2018

Original Report Date: June 2018

Report Number: 0135PS040E

All data and information contained in this report are confidential and proprietary to Hearth and Home Technologies. Its significance is subject to the adequacy and representative character of the samples and to the comprehensiveness of the tests, examinations, or surveys made. The contents of this report cannot be copied or quoted, except in full, without specific, written authorization from Hearth and Home Technologies and OMNI-Test Laboratories, Inc. No use of the OMNI-Test Laboratories, Inc. name, logo, or registered mark (O-TL) is permitted, except as expressly authorized by OMNI-Test Laboratories, Inc. in writing.

*Model: PP70
Hearth & Home Technologies
352 Mountain House Road
Halifax, PA 17032*

AUTHORIZED SIGNATORIES

This report has been reviewed and approved by the following authorized signatories:

Evaluation Decision:

A handwritten signature in black ink, appearing to read "Bruce Davis", is written over a horizontal line.

Bruce Davis, Testing Manager
OMNI-Test Laboratories, Inc.

TABLE OF CONTENTS

PREFACE	(3 pages)
1. SAMPLING PROCEDURES AND TEST RESULTS	p. 4
Introduction	p. 5
Sampling Procedure	p. 5
Summary of Results	p. 6
<u>Summary Tables</u>	
Table 1.1 – Particulate Emissions	p. 7
Table 1.2 – Efficiency and CO	p. 7
Table 1.3 – Test Facility Conditions	p. 8
Table 1.4 – Fuel Measurement Summary	p. 8
Table 1.5 – Dilution Tunnel and Flue Gas Measurements	p. 9
Table 1.6 – Heater Configuration	p. 9
2. PHOTOGRAPHS/APPLIANCE DESCRIPTION/DRAWINGS	p. 10
Photographs	p. 11
Appliance Description	p. 12
3. TEST DATA BY RUN	p. 13
Run 1	p. 16
4. QUALITY ASSURANCE/QUALITY CONTROL	p. 29
Sample Analysis	p. 31
Calibrations	p. 38
Example Calculations	p. 54
5. LABELING & OWNER’S MANUAL(S)	p. 69

*Model: PP70
Hearth & Home Technologies
352 Mountain House Road
Halifax, PA 17032*

Section 1

Sampling Procedures and Test Results

INTRODUCTION

Hearth and Home Technologies retained OMNI-Test Laboratories, Inc. (*OMNI*) to perform U.S. Environmental Protection Agency (EPA) certification testing on the PP70. The PP70 is a freestanding, pellet-fired room heater.

The testing was performed at *OMNI*'s testing facility in Portland, Oregon. The altitude of the laboratory is 30 feet above sea level. The unit was received in good condition and logged in at the *OMNI*'s testing facility on March 22, 2018. It was assigned and labeled with *OMNI* ID #2273. *OMNI* representative Bruce Davis conducted the certification testing and completed all testing by March 28, 2018.

This report is organized in accordance with the EPA-recommended outline and is summarized in the Table of Contents immediately preceding this section. The results in this report are limited to the item(s) submitted.

SAMPLING PROCEDURE

The PP70 was tested in accordance with the U.S. EPA 40 CFR Part 60, Subpart AAA – Standards of Performance for New Residential Wood Heaters using ASTM E2515 and ASTM E2779. The fuel used for certification testing was Lignetics pellet fuel; this fuel was graded as Premium by the Pellet Fuels Institute and was produced at registered mill # 03208. Particulate emissions were measured using dual sampling trains consisting of two sets of filters (front and back). The results of the integrated test run indicate an average particulate emission rate of 0.49 g/hr. The PP70 results are within the emission limit of 2.0 g/hr for affected facilities manufactured on or after May 15, 2020 or sold at retail after December 31, 2020.

The model PP70 was tested for thermal efficiency and carbon monoxide (CO) emissions in accordance with CSA B415.1-10. The heater has a demonstrated an average HHV thermal efficiency of 82.8% when tested with a 3” to 6” connector pipe adaptor as allowed by manufactureres installation instructions. The calculated CO emission rate was 0.066 g/min.

SUMMARY OF RESULTS

The average particulate emission rate over the complete, integrated test run was measured to be 0.49 g/hr.

The average particulate emission factor for the complete, integrated test run was measured to be 0.53 g/dry kg of fuel.

The average thermal efficiency for the complete, integrated test run was measured to be 82.8%.

The particulate emission rate calculated from the one-hour filter was 0.96 g/hr.

The proportionality results and sample train agreement for the test run was acceptable. Quality check results for each test run are presented in Section 3 of this report.

No anomalies were noted during the test series, negative probe assembly weights were found to be within ± 0.2 mg tare tolerance. Results were found to be valid and appropriate to specifications of ASTM 2515, and ASTM 2779.

SUMMARY TABLES

Table 1.1 – Particulate Emissions

	One-Hour Filter	Integrated Total
Emission Rate (g/hr)	0.96	0.49
Emission Factor (g/dry kg)	0.44	0.53

Table 1.2 – Efficiency and CO

	Burn Rate Segment			Integrated Total
	Maximum	Medium	Minimum	
Time (minutes)	60	120	180	360
Burn Rate (dry kg/hr)	2.18	0.79	0.60	0.93
Heat Output Rate (BTU/hr)	35,278	12,425	9,603	14,961
Heat Input Rate (BTU/hr)	42,535	15,429	11,676	18,071
Efficiency (%, HHV)	82.9	80.5	82.2	82.8
CO Emission Rate (g/min)	0.0468	0.0383	0.0907	0.0658

Table 1.3 – Test Facility Conditions

	Initial	Final
Room Temperature (°F)	76	72
Barometric Pressure (in Hg)	30.53	30.48
Air Velocity (ft/min)	< 50	< 50
Induced Draft (in H ₂ O)	0.0	0.0

Table 1.4 – Fuel Measurement Summary

Segment	Time (min)	Burn Rate (dry kg/hr)	Consumed Fuel Weight (lbs)	Fuel Moisture Content (dry basis - %)
Pretest	80	2.16	6.7	5.91
Maximum	60	2.18	5.1	5.91
Medium	120	0.79	3.7	5.91
Minimum	180	0.60	4.2	5.91
Integrated Total	360	0.93	13.0	5.91

Table 1.5 – Dilution Tunnel and Flue Gas Measurements

Segment	Average Flue Draft (in H ₂ O)	Average Dilution Tunnel Gas Measurements		
		Velocity (ft/sec)	Flow Rate (dscf/min)	Temperature (°F)
Integrated Total	-0.037	14.73	168.9	82

Table 1.6 – Heater Configuration

Segment	Heat Setting (Control Knob)	Trim Setting	Power Level (Shown in Program)
Pretest	Hi	+4	5
Maximum	Hi	+4	5
Medium	3	-1	2
Minimum	Lo	0	1

*Model: PP70
Hearth & Home Technologies
352 Mountain House Road
Halifax, PA 17032*

Section 2

Photographs Appliance Description Drawings

Model: PP70
Hearth & Home Technologies
352 Mountain House Road
Halifax, PA 17032

Hearth and Home Technologies PP70

PHOTOGRAPHS



PP70 Front



PP70 Back



PP70 Left

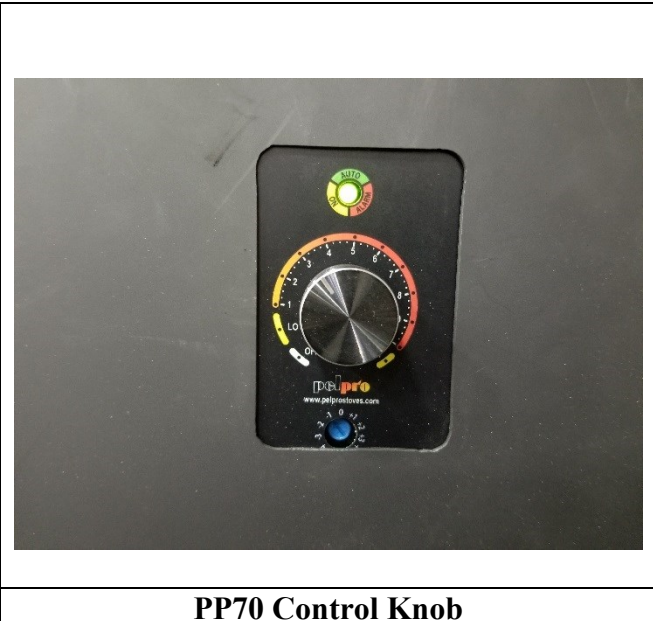

PP70 Control Knob

APPLIANCE DESCRIPTION

Appliance Manufacturer: Hearth and Home Technologies

Pellet Stove Model: PP70

Type: Freestanding, air-circulating type, pellet-fired room heater.

The PP70's principle elements include a fuel hopper, mild steel firebox chamber, Stainless Steel burn pot, and electrical fuel feed, combustion air, and convection air supply systems.

Air is drawn by the combustion air blower through a stainless-steel burn pot, holes are located on the sides and bottom that allows air to mix with the fuel from all sides. Combustion products are routed out of the firebox chamber through a 3-inch diameter flue outlet located on the rear of the unit.

Fuel is supplied from the hopper to the burn pot via an auger that carries pellets up from the hopper to a drop tube that routs pellets into the burn pot. Fuel supply rate is varied by cycling the auger motor on/off time as needed for desired heat output settings.

A door located on the front of the appliance is used primarily for cleaning and servicing the fire pot. A 5mm thick ceramic glass panel is utilized for viewing the fire, the door is sealed when closed by use of a 3/4" diameter rope gasket.

The electrical systems are regulated by a user-operated control board. On this board settings such as [insert settings] can be adjusted to achieve desired heat output. The unit is not designed to be controlled by an external thermostat system.

More detailed information is shown in the manufacturer's design drawings, Appendix C of this report. This information is considered confidential business information (CBI) by the manufacturer and is not included in the non-CBI version of this report.

*Model: PP70
Hearth & Home Technologies
352 Mountain House Road
Halifax, PA 17032*

Section 5

Test Data by Run

Test Instruction Recommendations: PP70

Created on/by: 03/19/18; C. Winslow Howe – HHT Design Engineer

Purpose: To create repeatability in test protocol of the stove.

Hopper Fuel: Hopper of the unit should be loaded up with a full 2 bags of fuel (Each bag weighing 40lb)

Test Settings: Unit should be set up using a 6in flue and 115VAC power source,

High: Dial should be set to 10 and the trim pot should be set to +4. When the unit is set and running at this setting the light above the dial control will Flash 5 times with a pause between each sequence

Medium: Dial should be set to 3 and the trim pot should be set to -1. When the unit is set and running at this setting the light above the dial control will flash 2 times with a pause between each sequence.

Low: Dial should be set to 1 and the trim pot should be set to 0. When the unit is set and running at this setting the light above the dial control will flash once with a pause between each flash.





Low

*Model: PP70
Hearth & Home Technologies
352 Mountain House Road
Halifax, PA 17032*

Run 1

Pellet Heater Conditioning Data - ASTM E2779

Manufacturer: Hearth & Home
 Model: PP70
 Tracking No.: 2273
 Project No.: 0135PS040E
 Test Date: 3/1/2018
 Operation Category: II - III - IV

Elapsed Time (hours)	Scale Reading (lbs)	Stack (°F)
0	4.3	197
1	2.0	155
2	1.9	146
3	1.4	133
4	1.5	126
5	1.4	128
6	4.1	196
7	1.9	156
8	1.8	144
9	1.3	131
10	1.4	128
11	1.4	126
12	4.4	241
13	2.0	181
14	2.0	177
15	1.4	145
16	1.4	149
17	1.3	155
18	4.4	245
19	2.0	186
20	1.9	173
21	1.5	162
22	1.5	158
23	1.5	159
24	4.3	244
25	2.0	181
26	1.7	170
27	1.5	161
28	1.4	153
29	1.4	155
30	4.0	240
31	2.0	184
32	1.9	174
33	1.5	157
34	1.5	153
35	1.4	151
36	4.3	244
37	2.0	181
38	1.7	170
39	1.5	161
40	1.4	151
41	1.4	153
42	4.0	240
43	2.1	184
44	1.9	174
45	1.5	157
46	1.5	155
47	1.4	151
48	4.0	241
49	2.2	182
50		



Pellet Heater Preburn Data - ASTM E2779

Manufacturer: Hearth & Home
 Model: PP70
 Tracking No.: 2273 PB Length: 80 min
 Project No.: 0135PS040E Recording Interval: 10 min
 Test Date: 3/28/2018

Averages:			256	73	0		
Elapsed Time (min)	Scale Reading	Weight Change	Stack (F)	Ambient (F)	Draft ("H2O)	CO2 (%)	CO (%)
0	47.9	-	234	69	-0.05		
10	46.3	-1.6	249	71	-0.05		
20	46.0	-0.3	257	72	-0.05		
30	45.1	-0.9	250	73	-0.05		
40	44.4	-0.7	255	74	-0.05		
50	43.9	-0.5	280	74	-0.05		
60	42.7	-1.2	257	75	-0.05		
70	42.1	-0.6	257	76	-0.05	7.87	0.01
80	41.2	-0.9	261	77	-0.05	8.29	0.02

Pellet Heater Test Data - ASTM E2779 / ASTM E2515

Run: 1

Manufacturer: Hearth & Home High Burn End Time: 60
 Model: PP70 Medium Burn End Time: 180
 Tracking No.: 2273 Total Sampling Time: 360 min
 Project No.: 0135PS040E Recording Interval: 10 min
 Test Date: 28-Mar-18
 Beginning Clock Time: 09:42 Background Sample Volume: 55.1 cubic feet

Meter Box Y Factor: 0.977 (1) 0.979 (2) 0.997 (Amb)

Barometric Pressure: Begin Middle End Average
30.53 30.48 30.51 "Hg

OMNI Equipment Numbers: _____

PM Control Modules: 335,336
 Dilution Tunnel MW(dry): 29.00 lb/lb-mole
 Dilution Tunnel MW(wet): 28.78 lb/lb-mole
 Dilution Tunnel H2O: 2.00 percent
 Dilution Tunnel Static: -0.200 "H2O
 Tunnel Area: 0.19635 ft²
 Pitot Tube Cp: 0.99

Avg. Tunnel Velocity: 14.73 ft/sec.
 Initial Tunnel Flow: 159.5 scfm
 Average Tunnel Flow: 168.9 scfm
 Post-Test Leak Check (1): 0.000 cfm @ 5 in. Hg
 Post-Test Leak Check (2): 0.000 cfm @ 6 in. Hg
 Fuel Moisture: 5.91 Dry Basis %

Velocity Traverse Data									
	Pt.1	Pt.2	Pt.3	Pt.4	Pt.5	Pt.6	Pt.7	Pt.8	Center
Initial dP	0.044	0.050	0.048	0.038	0.040	0.048	0.052	0.038	0.054
Temp:	92	92	92	92	92	92	93	93	92
V _{strav}	14.33			ft/sec			V _{scent}	15.59	
F _p	0.919								

Elapsed Time (min)	Particulate Sampling Data												Fuel Weight (lb)		Temperature Data (°F)				Stack Gas Data				
	Gas Meter 1 (ft ³)	Gas Meter 2 (ft ³)	Sample Rate 1 (cfm)	Sample Rate 2 (cfm)	Orifice dH 1 ("H ₂ O)	Meter Temp 1 (°F)	Meter Vacuum 1 ("Hg)	Orifice dH 2 ("H ₂ O)	Meter Temp 2 (°F)	Meter Vacuum 2 ("Hg)	Dilution Tunnel (°F)	Dilution Tunnel Center dP	Pro. Rate 1	Pro. Rate 2	Scale Reading	Weight Change	Stack	Filter 1	Filter 2	Ambient	Draft ("H ₂ O)	CO ₂ (%)	CO (%)
0	0.000	0.000			1.04	74	1.8	0.73	75	1.1	92	0.054			41.5		280	70	71	76	-0.053	5.62	0.0029
10	1.615	1.603	0.16	0.16	1.32	75	1.99	1.09	76	1.2	93	0.055	104	106	40.4	-1.1	255	73	73	77	-0.049	7.91	0.00999
20	3.230	3.197	0.16	0.16	1.36	77	2.11	1.06	78	1.2	93	0.053	105	107	39.7	-0.7	256	74	74	77	-0.050	8.74	0.00798
30	4.866	4.768	0.16	0.16	1.33	79	2.16	1.04	80	1.3	93	0.057	102	102	38.8	-0.9	260	75	75	77	-0.054	8.47	0.01048
40	6.507	6.348	0.16	0.16	1.34	80	2.2	1.05	81	1.3	91	0.054	105	105	38.0	-0.8	253	75	75	76	-0.051	7.92	0.00643
50	8.141	7.916	0.16	0.16	1.33	82	2.25	1.01	83	1.4	90	0.055	103	102	37.2	-0.8	255	75	75	77	-0.052	8.12	0.00484
60	9.782	9.511	0.16	0.16	1.34	82	2.35	1.06	83	1.5	90	0.060	99	100	36.4	-0.8	255	75	75	76	-0.052	8.15	0.01093
70	11.443	11.098	0.17	0.16	1.36	83	2.03	1.05	84	1.5	86	0.059	101	99	35.9	-0.5	213	76	75	76	-0.045	3.71	0.00329
80	13.099	12.685	0.17	0.16	1.36	83	2.03	1.05	84	1.5	83	0.055	104	103	35.6	-0.3	189	75	74	74	-0.040	3.73	0.00358
90	14.745	14.273	0.16	0.16	1.33	84	1.98	1.05	84	1.6	82	0.062	97	97	35.3	-0.3	184	74	74	74	-0.038	5.17	0.00192
100	16.378	15.861	0.16	0.16	1.32	83	1.97	1.05	84	1.6	82	0.058	99	100	35.0	-0.3	184	74	73	73	-0.038	4.76	0.00335
110	18.010	17.448	0.16	0.16	1.32	83	1.97	1.05	84	1.6	80	0.058	99	100	34.8	-0.2	176	73	73	73	-0.037	2.65	0.02169
120	19.649	19.035	0.16	0.16	1.33	83	1.98	1.05	84	1.6	80	0.060	98	98	34.5	-0.3	176	73	73	73	-0.036	2.43	0.02649
130	21.289	20.620	0.16	0.16	1.33	83	1.99	1.05	83	1.6	81	0.061	97	97	34.2	-0.3	181	73	72	73	-0.038	2.9	0.01161
140	22.925	22.202	0.16	0.16	1.32	83	1.99	1.04	83	1.6	80	0.056	101	101	33.9	-0.3	178	73	72	72	-0.037	3.45	0.00488
150	24.564	23.785	0.16	0.16	1.33	83	2	1.04	83	1.6	80	0.059	99	99	33.6	-0.3	179	73	72	72	-0.037	4.97	0.00367
160	26.202	25.367	0.16	0.16	1.33	83	2	1.04	83	1.6	81	0.059	99	99	33.3	-0.3	183	73	72	72	-0.038	3.88	0.00195
170	27.841	26.948	0.16	0.16	1.33	83	1.99	1.03	83	1.6	80	0.058	100	100	33.0	-0.3	177	73	72	73	-0.036	3.76	0.00287
180	29.478	28.528	0.16	0.16	1.32	83	2	1.04	83	1.6	80	0.059	99	99	32.7	-0.3	179	73	72	73	-0.037	3.84	0.00575
190	31.116	30.107	0.16	0.16	1.32	83	1.99	1.04	83	1.6	80	0.060	98	98	32.4	-0.3	172	73	72	73	-0.035	3.65	0.00163
200	32.755	31.686	0.16	0.16	1.33	83	2.01	1.03	83	1.6	78	0.054	103	103	32.2	-0.2	152	73	72	73	-0.030	2.07	0.05328
210	34.396	33.262	0.16	0.16	1.33	83	2.01	1.03	83	1.6	78	0.057	100	100	31.9	-0.3	151	73	72	72	-0.030	4.29	0.00544
220	36.035	34.836	0.16	0.16	1.34	83	2.02	1.03	83	1.6	80	0.058	100	99	31.8	-0.1	177	73	72	72	-0.033	3.41	0.00322
230	37.674	36.411	0.16	0.16	1.33	83	2.02	1.03	83	1.6	78	0.058	99	99	31.5	-0.3	152	73	72	72	-0.031	2.41	0.01366
240	39.312	37.984	0.16	0.16	1.33	83	2.02	1.02	83	1.6	77	0.059	98	98	31.3	-0.2	149	72	71	72	-0.030	1.75	0.104
250	40.950	39.555	0.16	0.16	1.34	83	2.03	1.03	83	1.6	81	0.060	98	97	31.0	-0.3	178	72	72	72	-0.038	4.44	0.00857
260	42.587	41.125	0.16	0.16	1.33	83	2.03	1.02	83	1.6	78	0.058	99	99	30.8	-0.2	150	72	72	72	-0.030	2.81	0.00727
270	44.223	42.693	0.16	0.16	1.32	83	2.03	1.02	83	1.6	78	0.059	98	98	30.6	-0.2	148	72	72	72	-0.030	2.65	0.00708
280	45.858	44.259	0.16	0.16	1.32	83	2.04	1.02	83	1.6	78	0.059	98	98	30.3	-0.3	151	72	72	72	-0.030	4.68	0.00319
290	47.492	45.855	0.16	0.16	1.32	83	2.03	1.08	83	1.7	78	0.058	99	100	30.1	-0.2	151	72	72	72	-0.030	3.39	0.03109
300	49.125	47.462	0.16	0.16	1.32	83	2.04	1.07	83	1.7	78	0.060	97	99	29.9	-0.2	151	72	72	72	-0.030	4.05	0.00309
310	50.760	49.066	0.16	0.16	1.37	83	2.1	1.06	83	1.7	77	0.059	98	100	29.7	-0.2	150	72	72	72	-0.031	4.17	0.00244
320	52.422	50.669	0.17	0.16	1.37	83	2.1	1.07	83	1.7	78	0.060	99	99	29.4	-0.3	152	72	72	72	-0.032	2.53	0.00837
330	54.083	52.271	0.17	0.16	1.37	83	2.11	1.07	83	1.7	77	0.058	101	101	29.1	-0.3	151	72	72	72	-0.032	5	0.00482
340	55.743	53.872	0.17	0.16	1.37	83	2.11	1.06	83	1.7	77	0.060	99	99	28.9	-0.2	150	72	72	72	-0.031	2.8	0.00727

Pellet Heater Test Data - ASTM E2779 / ASTM E2515

Run: 1

Manufacturer: Hearth & Home High Burn End Time: 60
 Model: PP70 Medium Burn End Time: 180
 Tracking No.: 2273 Total Sampling Time: 360 min
 Project No.: 0135PS040E Recording Interval: 10 min
 Test Date: 28-Mar-18
 Beginning Clock Time: 09:42 Background Sample Volume: 55.1 cubic feet

Meter Box Y Factor: 0.977 (1) 0.979 (2) 0.997 (Amb)

Barometric Pressure: Begin Middle End Average
30.53 30.48 30.51 "Hg

OMNI Equipment Numbers: _____

PM Control Modules: 335.336
 Dilution Tunnel MW(dry): 29.00 lb/lb-mole
 Dilution Tunnel MW(wet): 28.78 lb/lb-mole
 Dilution Tunnel H2O: 2.00 percent
 Dilution Tunnel Static: -0.200 "H2O
 Tunnel Area: 0.19635 ft2
 Pitot Tube Cp: 0.99

Avg. Tunnel Velocity: 14.73 ft/sec.
 Initial Tunnel Flow: 159.5 scfm
 Average Tunnel Flow: 168.9 scfm
 Post-Test Leak Check (1): 0.000 cfm @ 5 in. Hg
 Post-Test Leak Check (2): 0.000 cfm @ 6 in. Hg
 Fuel Moisture: 5.91 Dry Basis %

Velocity Traverse Data										
	Pt.1	Pt.2	Pt.3	Pt.4	Pt.5	Pt.6	Pt.7	Pt.8	Center	
Initial dP	0.044	0.050	0.048	0.038	0.040	0.048	0.052	0.038	0.054	"H2O
Temp:	92	92	92	92	92	92	93	93	92	°F
	V _{strav} <u>14.33</u> ft/sec			V _{scent} <u>15.59</u> ft/sec			F _p <u>0.919</u>			

Elapsed Time (min)	Particulate Sampling Data												Fuel Weight (lb)		Temperature Data (°F)				Stack Gas Data				
	Gas Meter 1 (ft³)	Gas Meter 2 (ft³)	Sample Rate 1 (cfm)	Sample Rate 2 (cfm)	Orifice dH 1 ("H2O)	Meter Temp 1 (°F)	Meter Vacuum 1 ("Hg)	Orifice dH 2 ("H2O)	Meter Temp 2 (°F)	Meter Vacuum 2 ("Hg)	Dilution Tunnel (°F)	Dilution Tunnel Center dP	Pro. Rate 1	Pro. Rate 2	Scale Reading	Weight Change	Stack	Filter 1	Filter 2	Ambient	Draft ("H2O)	CO2 (%)	CO (%)
350	57.403	55.473	0.17	0.16	1.37	83	2.11	1.06	83	1.7	77	0.062	97	97	28.7	-0.2	152	72	72	72	-0.032	2.29	0.0203
360	59.062	57.071	0.17	0.16	1.37	83	2.11	1.06	83	1.7	77	0.058	101	100	28.5	-0.2	152	72	71	72	-0.032	2.36	0.02733
Avg/Tot	59.062	57.071	0.16	0.16	1.33	82	2.05	1.04	82	1.56	82	0.06	100	100			184	73	73	73	-0.037	4.30	0.01

Pellet Heater Lab Data - ASTM E2779 / ASTM E2515

Manufacturer: <u>Hearth & Home</u>	Equipment Numbers: <u>23, 283A, 592</u>
Model: <u>PP70</u>	
Tracking No.: <u>2273</u>	
Project No.: <u>0135PS040E</u>	
Run #: <u>1</u>	
Date: <u>3/28/18</u>	

TRAIN 1 (First Hour emissions)

Sample Component	Reagent	Filter, Probe or Dish #	Weights		
			Final, mg	Tare, mg	Particulate, mg
A. Front filter catch	Filter	D475	116.2	115.3	0.9
B. Rear filter catch	Filter				0.0
C. Probe catch*	Probe				0.0
D. Filter seals catch*	Seals				0.0

Sub-Total	Total Particulate, mg:	0.9
-----------	------------------------	-----

TRAIN 1 (Remainder of Test)

Sample Component	Reagent	Filter, Probe or Dish #	Weights		
			Final, mg	Tare, mg	Particulate, mg
A. Front filter catch	Filter	D476	117.7	116.1	1.6
B. Rear filter catch	Filter	D477	115.0	115.1	-0.1
C. Probe catch*	Probe	31	114368.8	114368.9	0.0
D. Filter seals catch*	Seals	R596	4090.7	4090.4	0.3

Sub-Total	Total Particulate, mg:	1.8
-----------	------------------------	-----

Train 1 Aggregate	Total Particulate, mg:	2.7
-------------------	------------------------	-----

TRAIN 2

Sample Component	Reagent	Filter, Probe or Dish #	Weights		
			Final, mg	Tare, mg	Particulate, mg
A. Front filter catch	Filter	D478	115.6	112.7	2.9
B. Rear filter catch	Filter	D479	113.1	113.2	-0.1
C. Probe catch*	Probe	32	114741.4	114741.4	0.0
D. Filter seals catch*	Seals	R597	3370.5	3370.6	0.0

Total Particulate, mg:	2.8
------------------------	-----

AMBIENT

Sample Component	Reagent	Filter # or Probe #	Weights		
			Final, mg	Tare, mg	Particulate, mg
A. Front filter catch*	Filter		113.3	113.3	0.0

Total Particulate, mg:	0.0
------------------------	-----

*Particulate catch that results in a negative number, is assumed to be zero for probes and seals, negative numbers for filters are assumed to be part of the seal weight.

Component	Equations:
A. Front filter catch	Final (mg) - Tare (mg) = Particulate, mg
B. Rear filter catch	Final (mg) - Tare (mg) = Particulate, mg
C. Probe catch	Final (mg) - Tare (mg) = Particulate, mg

Pellet Heater Test Results - ASTM E2779 / ASTM E2515

Manufacturer: Hearth & Home
 Model: PP70
 Project No.: 0135PS040E
 Tracking No.: 2273
 Run: 1
 Test Date: 03/28/18

Burn Rate (Composite)	0.93 kg/hr dry
Average Tunnel Temperature	82 degrees F
Average Gas Velocity in Dilution Tunnel - vs	14.73 feet/second
Average Gas Flow Rate in Dilution Tunnel - Qsd	10133.2 dscf/hour
Average Delta p	0.058 inches H2O
Average Delta H	1.33 inches H2O
Total Time of Test	360 minutes

Burn Rate (High)	2.18 kg/hr dry
Burn Rate (Med)	0.79 kg/hr dry 36.3% of High
Burn Rate (Low)	0.60 kg/hr dry 27.5% of High

	AMBIENT	SAMPLE TRAIN 1	SAMPLE TRAIN 2	1 st HR FILTER (TRAIN 1)
Total Sample Volume - Vm	55.100 cubic feet	59.062 cubic feet	57.071 cubic feet	9.782 cubic feet
Average Gas Meter Temperature	73 degrees F	82 degrees F	82 degrees F	82 degrees F
Total Sample Volume (Standard Conditions) - Vmstd	55.430 dscf	57.456 dscf	55.560 dscf	9.516 dscf
Total Particulates - m _n	0 mg	2.7 mg	2.8 mg	0.9 mg
Particulate Concentration (dry-standard) - C _p /C _s	0.000000 grams/dscf	0.00005 grams/dscf	0.00005 grams/dscf	0.00009 grams/dscf
Total Particulate Emissions - E _T	0.00 grams	2.86 grams	3.06 grams	0.96 grams
Particulate Emission Rate	0.00 grams/hour	0.48 grams/hour	0.51 grams/hour	0.96 grams/hour
Emissions Factor		0.51 g/kg	0.55 g/kg	0.44 g/kg
Difference from Average Total Particulate Emissions		0.10 grams	0.10 grams	
Dual Train Comparison Results Are Acceptable				

FINAL AVERAGE RESULTS

Integrated Test Run	
Total Particulate Emissions - E _T	2.96 grams
Particulate Emission Rate	0.49 grams/hour
Emissions Factor	0.53 grams/kg
First Hour Emissions	
Total Particulate Emissions - E _T	0.96 grams
Particulate Emission Rate	0.96 grams/hour
Emissions Factor	0.44 grams/kg

QUALITY CHECKS

Filter Temps < 90 °F	OK
Filter Face Velocity (47 mm)	OK
Leakage Rate	OK
Ambient Temp (55-90°F)	OK
Negative Probe Weight Eval.	OK
Pro-Rate Variation	OK
Total PM Precision (%)	5.24
Train A - Train B G/KG ≤ 0.5	0.04
Medium Burn Rate < 50%	OK

OMNI-Test Laboratories

Manufacturer: Hearth & Home
Model: PP70
Date: 03/28/18
Run: 1
Control #: 0135PS040E
Test Duration: 360
Output Category: Integrated

Technicians: _____

Test Results in Accordance with CSA B415.1-09

	HHV Basis	LHV Basis
Overall Efficiency	82.8%	88.5%
Combustion Efficiency	99.5%	99.5%
Heat Transfer Efficiency	83%	88.9%

Output Rate (kJ/h)	15,771	14,961	(Btu/h)
Burn Rate (kg/h)	0.93	2.05	(lb/h)
Input (kJ/h)	19,050	18,071	(Btu/h)

Test Load Weight (dry kg)	5.57	12.27	dry lb
MC wet (%)	5.580209612		
MC dry (%)	5.91		
Particulate (g)	2.96		
CO (g)	24		
Test Duration (h)	6.00		

Emissions	Particulate	CO
g/MJ Output	0.03	0.25
g/kg Dry Fuel	0.53	4.25
g/h	0.49	3.95
lb/MM Btu Output	0.07	0.58

Air/Fuel Ratio (A/F)	28.44
-----------------------------	-------

VERSION: 2.2 12/14/2009



OMNI-Test Laboratories

Manufacturer: Hearth & Home
Model: PP70
Date: 03/28/18
Run: 1
Control #: 0135PS040E
Test Duration: 60
Output Category: Maximum

Technicians: B. W. [Signature]

Test Results in Accordance with CSA B415.1-09

	HHV Basis	LHV Basis
Overall Efficiency	82.9%	88.6%
Combustion Efficiency	99.5%	99.5%
Heat Transfer Efficiency	83%	89.1%

Output Rate (kJ/h)	37,190	35,278	(Btu/h)
Burn Rate (kg/h)	2.18	4.82	(lb/h)
Input (kJ/h)	44,840	42,535	(Btu/h)

Test Load Weight (dry kg)	2.18	4.82	dry lb
MC wet (%)	5.580209612		
MC dry (%)	5.91		
Particulate (g)	0		
CO (g)	3		
Test Duration (h)	1.00		

Emissions	Particulate	CO
g/MJ Output	0.00	0.08
g/kg Dry Fuel	0.00	1.28
g/h	0.00	2.81
lb/MM Btu Output	0.00	0.18

Air/Fuel Ratio (A/F)	15.60
-----------------------------	-------

VERSION:

2.2

12/14/2009

OMNI-Test Laboratories

Manufacturer: Hearth & Home
Model: PP70
Date: 03/28/18
Run: 1
Control #: 0135PS040E
Test Duration: 120
Output Category: Medium

Technicians: B. [Signature]

Test Results in Accordance with CSA B415.1-09

	HHV Basis	LHV Basis
Overall Efficiency	80.5%	86.0%
Combustion Efficiency	99.5%	99.5%
Heat Transfer Efficiency	81%	86.5%

Output Rate (kJ/h)	13,099	12,425	(Btu/h)
Burn Rate (kg/h)	0.79	1.75	(lb/h)
Input (kJ/h)	16,265	15,429	(Btu/h)

Test Load Weight (dry kg)	1.59	3.49	dry lb
MC wet (%)	5.580209612		
MC dry (%)	5.91		
Particulate (g)	0		
CO (g)	5		
Test Duration (h)	2.00		

Emissions	Particulate	CO
g/MJ Output	0.00	0.18
g/kg Dry Fuel	0.00	2.90
g/h	0.00	2.30
lb/MM Btu Output	0.00	0.41

Air/Fuel Ratio (A/F)	29.77
-----------------------------	-------

VERSION:

2.2

12/14/2009

Client: Hearth & Home Technologies Project Number: 0135 P50 40E Run Number: 1

Model: PP70 Tracking Number: 2273 Date: 3/28/2018

Test Crew: B. Davis
 OMNI Equipment ID numbers: 592, 637, 283A, 559, 410, 335, 336, 594, 296-T59, 132

Pellet Heater Run Notes

Air Control Settings

High Burn Rate Target: Max
 Settings: Heat setting MAX, Power Level 5, trim setting +4

Medium Burn Rate Target: 450% of max
 Settings: Heat setting 3, Power Level 2, trim setting -1.

Low Burn Rate Target: Minimum
 Settings: Power Heat setting 40, Power Level 1, trim setting 0

Additional Settings Notes:
N/A

Preburn Notes

Time	Notes
<u>0</u>	<u>Heat setting MAX, Power Level 5 trim setting + 4</u>

Test Notes

Time	Notes
<u>60</u>	<u>Changed front filter in train A. Adjusted Heat setting to 3, Power Level 2, trim -1.</u>
<u>180</u>	<u>Adjusted Heat setting to 40, Power Level 1, trim setting 0.</u>

Pellet Moisture Content: 5.91 db

Technician Signature: [Signature]
 Control No. P-SFDL-0001, Effective Date: 6/8/2015 of 110

Date: 4/9/18 Page 1 of 3

ASTM E2779 Pellet Heater Run Sheets

Client: Hearth & Home Technologies Project Number: 0135R040E Run Number: 1

Model: PP70 Tracking Number: 2273 Date: 3/28/2018

Test Crew: B. Davis

OMNI Equipment ID numbers: 592, 637, 283A, 559, 410, 335, 336, 594, 296-T59, 132

Pellet Heater Supplemental Data

Start Time: 0942 Booth #: E1

Stop Time: 1542

Stack Gas Leak Check:

Initial: good Final: good

Sample Train Leak Check:

A: 0.0 @ 6 "Hg
B: 0.0 @ 5 "Hg

Calibrations: Span Gas

CO₂: 9.97/0.97 16.78 CO: 2.50/901 4.244

	Pre Test		Post Test	
	Zero	Span	Zero	Span
Time	<u>0913</u>	<u>0913</u>	<u>1546</u>	<u>1546</u>
CO ₂	<u>0.00</u>	<u>10.14/0.98</u>	<u>0.00</u>	<u>10.08/0.96</u>
CO	<u>0.000/0</u>	<u>2.540/901</u>	<u>0.000/0</u>	<u>2.531/896</u>

Air Velocity (ft/min): Initial: 450 Final: 450

Scale Audit (lbs): Initial: 10.0 Final: 10.0

Pitot Tube Leak Test: Initial: good Final: good

Stack Diameter (in): 6"

Induced Draft: 0.0

% Smoke Capture: 100%

Flue Pipe Cleaned Prior to First Test in Series:

Date: 3/28/18 Initials: AD

	Initial	Middle	Ending
P _b (in/Hg)	<u>30.53</u>	<u>N/A</u>	<u>30.44</u>
Ambient (°F)	<u>76</u>		<u>72</u>

Tunnel Traverse		
Microtector Reading	dP (in H ₂ O)	T(°F)
	<u>.044</u>	<u>92</u>
	<u>.050</u>	<u>92</u>
	<u>.048</u>	<u>92</u>
	<u>.038</u>	<u>92</u>
	<u>.040</u>	<u>92</u>
	<u>.048</u>	<u>92</u>
	<u>.052</u>	<u>93</u>
	<u>.038</u>	<u>93</u>
Center:		
	<u>.054</u>	<u>92</u>
Static:		
	<u>-.20</u>	

Background Filter Volume: 55.100

Technician Signature: [Signature]
Control No. P-SFDL-0001, Effective Date: 6/8/2015

Date: 4/9/18

*Model: PP70
Hearth & Home Technologies
352 Mountain House Road
Halifax, PA 17032*

Section 4

Quality Assurance/Quality Control

QUALITY ASSURANCE/QUALITY CONTROL

OMNI follows the guidelines of ISO/IEC 17025, “General Requirements for the Competence of Testing and Calibration Laboratories,” and the quality assurance/quality control (QA/QC) procedures found in OMNI’s Quality Assurance Manual.

OMNI’s scope of accreditation includes, but is not limited to, the following:

- ANSI (American National Standards Institute) for certification of product to safety standards.
- To perform product safety testing by the International Accreditation Service, Inc. (formerly ICBO ES) under accreditation as a testing laboratory designated TL-130.
- To perform product safety testing as a “Certification Organization” by the Standards Council of Canada (SCC).
- Serving as a testing laboratory for the certification of wood heaters by the U.S. Environmental Protection Agency.

This report is issued within the scope of OMNI’s accreditation. Accreditation certificates are available upon request.

The manufacturing facilities and quality control system for the production of the PP70 at Hearth and Home Technologies were evaluated to determine if sufficient to maintain conformance with OMNI’s requirements for product certification. OMNI has concluded that the manufacturing facilities, processes, and quality control system are adequate to produce the appliance congruous with the standards and model codes to which it was evaluated.

This report shall not be reproduced, except in full, without the written approval of OMNI-Test Laboratories, Inc.

*Model: PP70
Hearth & Home Technologies
352 Mountain House Road
Halifax, PA 17032*

Sample Analysis
Analysis Worksheets
Moisture Content Worksheet
Fuel Certification Label
Tared Filter, Probe, and O-Ring Data

Tare Sheet: Probes 47mm Filters 100mm Filters O-Ring Pair

Date/time Placed in Dessicator: 3/21/18 1458

Thermohyrometer ID #: Omni-0592

Prepared By: B Davis

Analytical Balance ID #: Omni-0637

Audit Weight ID #/Mass: Omni-00283A / 200mg

ID #	Date: 3/22/18 Time: 0909 1515 RH %: 28.4 T (°F): 68.7 Audit: 200.0	Date: 3/23/18 Time: 0828 RH %: 19.5 T (°F): 68.1 Audit: 200.0	Date: Time: RH %: T (°F): Audit:	Date: Time: RH %: T (°F): Audit:	Date Used	Project Number	Run No.
D469	115.5	115.3	✓		3/26/18	0041 0135PS041E	1
D470	115.8	115.7					
D471	114.7	114.7	✓				
D472	116.2	116.4	✓				
D473	116.4	116.2	✓				
D474	116.0	116.0	✓				
D475	115.3	115.3	✓		3/28/18	0041 0135PS041E	1
D476	116.2	116.1	✓				
D477	115.0	115.1	✓				
D478	112.7	112.7	✓				
D479	113.2	113.2	✓				
D480	113.3	113.3	✓				
D481	113.6	113.4	✓				
D482	112.9	112.9	✓				
D483	112.6	112.6	✓				
D484	112.2	112.3	✓				
D485	113.3	113.1	✓				
D486	112.3	112.5	✓				
D487	112.7	112.6	✓				
D488	111.6	111.7	✓				
D489	112.9	113.0	✓				
D490	112.1	112.1	✓				
Initials: <u>BD</u>		Initials: <u>BD</u>		Initials: <u> </u>		Initials: <u> </u>	

Final Technician Signature: BD
Control No. P-SFDP-0001.xls, Effective date: 9/9/2015

Date: 3/23/18
32 of 110

Evaluator signature: [Signature]

Tare Sheet: Probes 47mm Filters 100mm Filters O-Ring Pair

Date/time Placed in Dessicator: 3/5/18 0840

Thermohyrometer ID #: Omw-00592

Prepared By: B Dams

Analytical Balance ID #: Omw-0037

Audit Weight ID #/Mass: Omw-00283A / 100 g

ID #	Date: <u>3/4/18</u>				Date Used	Project Number	Run No.
	Date: <u>0856 0854</u>	Date: <u>3/9/18</u>	Date:	Date:			
	Time: <u>0930</u>	Time: <u>0856</u>	Time: <u>0836</u>	Time:			
	RH %: <u>9.4</u>	RH %: <u>10.4</u>	RH %: <u>12.0</u>	RH %:			
	T (°F): <u>66.4</u>	T (°F): <u>67.8</u>	T (°F): <u>68.3</u>	T (°F):			
	Audit: <u>99.9991</u>	Audit: <u>99998.1</u>	Audit: <u>99998.1</u>	Audit:			
6	115349.9	115349.6	115349.6	✓			
7	114981.5	114981.5		✓			
8	115593.9	115593.8		✓			
9	115672.5	115672.5		✓			
11	114187.8	114187.7		✓			
13	114321.7	114321.5		✓			
14	114549.6	114549.4		✓			
21	114892.7	114892.5		✓			
22	114344.4	114344.2		✓			
23	114077.6	114077.2	114077.4	✓			
24	114127.3	114127.1		✓			
25	114277.7	114277.6		✓			
28	114751.1	114751.1		✓			
29	114278.4	114278.1	114278.3	✓	<u>3/20/18</u>	<u>0010135P5041P</u>	<u>1</u>
30	114329.3	114329.2		✓			
31	114368.7	114368.4		✓			
32	114741.5	114741.4		✓	<u>3/21/18</u>	<u>00510135P5041P</u>	<u>1</u>
33	113740.7	113740.8		✓			
35	114327.0	114327.1		✓			
36	114884.8	114884.6		✓			
37	114465.4	114465.6		✓			
38	114150.9	114151.0		✓			
	Initials: <u>BD</u>	Initials: <u>BD</u>	Initials: <u>ML</u>	Initials:			

Final Technician Signature: [Signature]
 Control No. P-SFDP-0001.xls, Effective date: 9/9/2015

Date: 3/14/18
33 of 1102

Evaluator signature: [Signature]

Model: PP70 Tracking Number: 2273 Date: 3/28/2018

Test Crew: B. Davis
 OMNI Equipment ID numbers: 592, 637, 283A, 559, 410, 335, 336, 594, 296-T59, 132

ASTM E2515 Lab Sheet

Assembled By:

B. Davis

Date/Time in Desiccator:

3/28/18 1605

Weighing #1	Weighing #2	Weighing #3	Weighing #4	Weighing #5
Date: <u>3/29/18</u>	Date: <u>4/2/18</u>	Date: <u>4/3/18</u>	Date:	Date:
Time: <u>1630</u>	Time: <u>0802</u>	Time: <u>0807</u>	Time:	Time:
R/H %: <u>20.4</u>	R/H %: <u>15.2</u>	R/H %: <u>14.1</u>	R/H %:	R/H %:
Temp: <u>69.8</u>	Temp: <u>69.4</u>	Temp: <u>71.6</u>	Temp:	Temp:
Audit: <u>99998.0</u>	Audit: <u>99997.9</u>	Audit: <u>99997.9</u>	Audit:	Audit:
Initials: <u>BL</u>	Initials: <u>BL</u>	Initials: <u>BL</u>	Initials:	Initials:

Train	Element	ID #	Tare (mg)	Weight (mg)	Weight (mg)	Weight (mg)	Weight (mg)	Weight (mg)
A	Front Filter (60 min)	D475	115.3	116.2	116.2	-		
A	Front Filter (Remainder)	D476	116.1	117.6	117.7	-		
A	Rear Filter	D477	115.1	114.9	115.0	-		
A	Probe	31	114368.9	114368.9	114368.8	-		
A	O-Ring Set	R596	4090.4	4091.3	4090.5	4090.7	-	
B	Front Filter	D478	112.7	115.6	115.6	-		
B	Rear Filter	D479	113.2	113.0	113.1	-		
B	Probe	32	114741.4	114741.5	114741.4	-		
B	O-Ring Set	R597	3370.6	3370.8	3370.6	3370.5	-	
BG	Filter	D480	113.3	112.9	113.2	113.3	-	



Twin Ports Testing, Inc.
 1301 North 3rd Street
 Superior, WI 54880
 p: 715-392-7114
 p: 800-373-2562
 f: 715-392-7163
 www.twinportstesting.com

Report No: USR:W218-0140-01
Issue No: 1

Analytical Test Report

Client: OMNI-TEST LABORATORIES INC.
 13327 NE Airport Way
 Portland, OR 97230
Attention: Finance Department
PO No: 180165

Signed: *Stephen Sundeen*
 Stephen Sundeen
 Chemistry Laboratory Manager
 Date of Issue: 2/27/2018
THIS DOCUMENT SHALL NOT BE REPRODUCED EXCEPT IN FULL

Sample Details
Sample Log No: W218-0140-01 **Sample Date:**
Sample Designation: 03208-2018 **Sample Time:**
Sample Recognized As: Wood Pellets **Arrival Date:** 2/13/2018

Test Results

	METHOD	UNITS	MOISTURE FREE	AS RECEIVED
Moisture Total	ASTM E871	wt. %		5.58
Ash	ASTM D1102	wt. %	0.34	0.32
Volatile Matter	ASTM D3175	wt. %		
Fixed Carbon by Difference	ASTM D3172	wt. %		
Sulfur	ASTM D4239	wt. %	0.007	0.007
SO ₂	Calculated	lb/mmbtu		0.015
Net Cal. Value at Const. Pressure	ISO 1928	GJ/tonne	19.20	17.99
Net Cal. Value at Const. Pressure	ISO 1928	J/g	19197	17989
Gross Cal. Value at Const. Vol.	ASTM E711	J/g	20523	19377
Gross Cal. Value at Const. Vol.	ASTM E711	Btu/lb	8824	8331
Carbon	ASTM D5373	wt. %	50.70	47.87
Hydrogen*	ASTM D5373	wt. %	6.09	5.75
Nitrogen	ASTM D5373	wt. %	< 0.20	< 0.19
Oxygen*	ASTM D3176	wt. %	> 42.66	> 40.27

*Note: As received values do not include hydrogen and oxygen in the total moisture.

Chlorine	ASTM D6721	mg/kg		
Fluorine	ASTM D3761	mg/kg		
Mercury	ASTM D6722	mg/kg		

Bulk Density	ASTM E873	lbs/ft ³		
Fines (Less than 1/8")	TPT CH-P-06	wt. %		
Durability Index	Kansas State	PDI		
Sample Above 1.50"	TPT CH-P-06	wt. %		
Maximum Length (Single Pellet)	TPT CH-P-06	inch		
Diameter, Range	TPT CH-P-05	inch		to
Diameter, Average	TPT CH-P-05	inch		
Stated Bag Weight	TPT CH-P-01	lbs		
Actual Bag Weight	TPT CH-P-01	lbs		

Comments

36 of 110

CLEAN • EFFICIENT



**PFI Densified Fuel Grade: Premium
Mill Registration # 03208
Grade Requirements:**

Bulk Density:	40-48 lbs/ft ³
Diameter:	230-285 in/5.84-7.25 mm
Durability:	≥96.5
Fines:	≤0.50%
Ash Content (as received):	≤1%
Length:	>1.5 in.
Moisture:	≤8.0%
Chlorides:	≤300 ppm

Manufacturers Guaranteed Analysis:

Type of Material:	Softwood
Additives:	None
Minimum Higher Heating Value (as received):	8000 BTU/lb.
Other Manufacturers Guarantees:	



For more information, please visit the PFI website at www.pelletheat.org.

This
Calif
like v
and
Calif
har
dus

Calibrations

EPA Method 28R, ASTM E2515, ASTM E2779

ID #	Lab Name/Purpose	Log Name	Attachment Type
132	10 lb Weight	Weight Standard, 10 lb.	Calibration Certificate
185	Platform Scale	Weight Indicator, Model WI-127	Calibration Certificate
209	Barometer	Barometer – Princo	Equipment Record
283A	Audit Weights	Troemner 21pc Msas Set	Calibration Certificate
335	Sample Box / Dry Gas Meter	Apex Automated Emissions Sampling Box	Calibration Log
336	Sample Box / Dry Gas Meter	Apex Automated Emissions Sampling Box	Calibration Log
410	Microtector	Dwyer Microtector	Calibration Certificate
559	Vaneometer	Dwyer Vaneometer	Equipment Record
592	Thermohygrometer	Omega Digital Thermohygrometer	Calibration Log
594	Combustion Gas Analyzer	CAI Gas Analyzer	See Run Sheet
637	Analytical Balance	Analytical Balance - Mettler - Toledo	Calibration Certificate

SCALE WEIGHT CALIBRATION DATA SHEET

Weight to be calibrated: 10 pounds

ID Number: OMNI-00132

Standard Calibration Weight: 10 pounds

ID Number: OMNI-00255

Scale Used: MTW-150K

ID Number: OMNI-00353

Date: 2/23/2018 By: B. Davis

Standard Weight (A) (Lb.)	Weight Verified (B) (Lb.)	Difference (A - B)	% Error
10.0	10.0	0.0	0

*Acceptable tolerance is 1%.

This calibration is traceable to NIST using calibrated standard weights.

Technician signature:  Date: 2/23/18



QUALITY CONTROL SERVICES

LABORATORY EQUIPMENT • SALES • SERVICE • CALIBRATION • REPAIRS
 2340 SE 11TH Ave. Portland, Oregon 97214 • Box 14831 Portland, Oregon 97293
 (503) 236-2712 • FAX (503) 235-2535 • www.qc-services.com



OMNI-Test Laboratories, Inc.
 13327 NE Airport Way
 Portland, OR 97230

Report Number: OMNE0321676171004

A2LA ACCREDITED CERTIFICATE OF CALIBRATION WITH DATA

INSTRUMENT INFORMATION

Item	Make	Model	Serial Number	Customer ID	Location
Scale	Weigh-Tronix	WI-127 1000x0.1lb	21676	185	Lab
Units	Readability	SOP	Cal Date	Last Cal Date	Cal Due Date
lbs	0.1	QC033	10/4/17	10/11/16	10/2018

FUNCTIONAL CHECKS

SHIFT TEST		LINEARITY		REPEATABILITY		ENVIRONMENTAL CONDITIONS
Test Wt:	Tol:	Test Wt:	Tol:	Test Wt:	Tol:	<input type="checkbox"/> Good <input checked="" type="checkbox"/> Fair <input type="checkbox"/> Poor Temperature: 21.0°C
500	0.5	HB44	HB44	200	0.2	
As-Found:		As-Found:		As-Found:		
Pass: <input checked="" type="checkbox"/>	Fail: <input type="checkbox"/>	Pass: <input checked="" type="checkbox"/>	Fail: <input type="checkbox"/>	Pass: <input checked="" type="checkbox"/>	Fail: <input type="checkbox"/>	
As-Left:		As-Left:		As-Left:		
Pass: <input checked="" type="checkbox"/>	Fail: <input type="checkbox"/>	Pass: <input checked="" type="checkbox"/>	Fail: <input type="checkbox"/>	Pass: <input checked="" type="checkbox"/>	Fail: <input type="checkbox"/>	

CALIBRATION DATA

Standard	As-Found	As-Left	Expanded Uncertainty
1000	1000.0	1000.0	0.12
700	700.0	700.0	0.12
500	500.0	500.0	0.08
200	200.0	200.0	0.08
100	100.0	100.0	0.05
50	50.0	50.0	0.05

CALIBRATION STANDARDS

Item	Make	Model	Serial Number	Cal Date	Cal Due Date	NIST ID
Avoirdupois Cast W	Rice Lake	25 and 50lb	PWO990-CA	11/4/15	11/2017	20152112

Permanent Information Concerning this Equipment:

Comments/Information Concerning this Calibration

Report prepared/reviewed by: ① Date: 10-4-17

Technician: D. Oudeans

Signature: [Signature]

THIS CERTIFICATE SHALL NOT BE REPRODUCED, EXCEPT IN FULL, WITHOUT THE APPROVAL OF QUALITY CONTROL SERVICES, INC.

The uncertainty is calculated according to the ISO Guide to the Expression of Uncertainty in Measurement and includes the uncertainty of standards used combined with the observed standard deviation of the unit under test. The uncertainty is expanded with a k factor of 2 for an approximate 95% level of confidence. Instruments listed above were calibrated using standards traceable to the National Institute of Standards and Technology (NIST). Calibration data reflect results at the time and location of calibration. Calibration data should be reviewed to insure that the instrument is performing to its required accuracy.

OMNI 00209

Instruction Booklet

for use with

PRINCO

Fortin type mercurial

Barometers

Manufactured by

PRINCO INSTRUMENTS, INC.

1020 Industrial Blvd.

Southampton, Pa. 18966-4095

U.S.A.

Phone: 215 355-1500

Fax: 215 355-7766



453
National
Weather
Service
Type

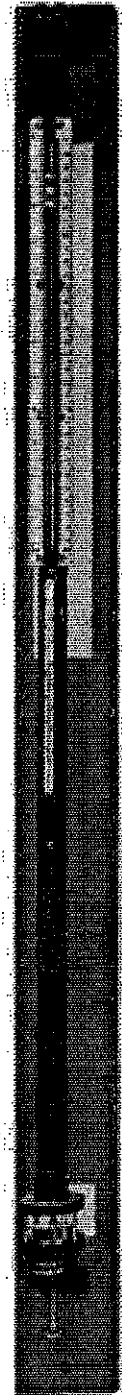

463
NOVA™
Economy
Model

Thermal Metering System Calibration Y Factor

Manufacturer: APEX
 Model: XC-60-EP
 Serial Number: 606001
 OMNI Tracking No.: OMNI-00335
 Calibrated Orifice: Yes

Date	7/18/2017	Acceptable Deviation (5%)	Deviation
y Factor	0.981	0.04905	0.004
Acceptance	Acceptable		

Average Gas Meter y Factor 0.977
--

Orifice Meter dH@ N/A

Acceptable y Deviation	0.020
Maximum y Deviation	0.005
Acceptable dH@ Deviation	N/A
Maximum dH@ Deviation	N/A
Acceptance	Acceptable

Calibration Date: 01/17/18
 Calibrated by: B. Davis
 Calibration Frequency: Six months
 Next Calibration Due: 7/18/2018
 Instrument Range: 1.000 cfm
 Standard Temp.: 68 oF
 Standard Press.: 29.92 "Hg
 Barometric Press., Pb: 29.94 "Hg
 Signature/Date:  1/18/2018

Standard	Model	Standard Test Meter
Calibrator	S/N	<u>OMNI-00001</u>
	Calib. Date	<u>30-Oct-17</u>
	Calib. Value	<u>0.9977</u> y factor (ref)

 1/19/2018

Calibration Parameters	Run 1	Run 2	Run 3
Reference Meter Pressure ("H2O), Pr	0.00	0.00	0.00
DGM Pressure ("H2O), Pd	2.30	1.38	1.00
Initial Reference Meter	198.1	203.7	214.2
Final Reference Meter	203.602	208.8	222.5
Initial DGM	0	0	0
Final DGM	5.65	5.298	8.67
Temp. Ref. Meter (°F), Tr	68.1	68.1	68.0
Temperature DGM (°F), Td	77.0	78.0	80.0
Time (min)	26.5	31.8	43.5
Net Volume Ref. Meter, Vr	5.502	5.100	8.300
Net Volume DGM, Vd	5.65	5.298	8.67
Gas Meter y Factor =	0.982	0.975	0.974
Gas Meter y Factor Deviation (from avg.)	0.005	0.002	0.003
Orifice dH@	N/A	N/A	N/A
Orifice dH@ Deviation (from avg.)	N/A	N/A	N/A

where:

1. Deviation = |Average value for all runs - current run value|
- ** 2. $y = [Vr \times (y \text{ factor (ref)}) \times (Pb + (Pr / 13.6)) \times (Td + 460)] / [Vd \times (Pb + (Pd / 13.6)) \times (Tr + 460)]$
- ** 3. $dH@ = 0.0317 \times Pd / (Pb (Td + 460)) \times [(Tr + 460) \times \text{time}] / Vr^2$

* Reference calibration is traceable to NIST through NIST Test # 40674, Kimble ASTM E1272, or NIST traceable laboratory

** Equations come from EPA Method 5

The uncertainty of measurement is $\pm 0.14 \text{ ft}^3/\text{min}$. This is based on the reference standard having a TAR (Test Accuracy Ratio) of at least 4:1.

DIFFERENTIAL PRESSURE GAUGE CALIBRATION DATA SHEET

Instrument to be calibrated: Pressure Transducer

Maximum Range: 0-2" WC ID Number: OMNI-00335

Calibration Instrument: Digital Manometer ID Number: OMNI-00395

Date: 1/17/2018 By: B. Davis

This form is to be used only in conjunction with Standard Procedure C-SPC.

Range of Calibration Point ("WC)	Digital Manometer Input ("WC)	Pressure Gauge Response ("WC)	Difference (Input - Response)	% Error of Full Span*
0-20% Max. Range 0 - 0.4	0.08	0.067	0.013	0.65
20-40% Max. Range 0.4 - 0.8	0.64	0.638	0.002	0.10
40-60% Max. Range 0.8 - 1.2	1.00	1.012	0.012	0.60
60-80% Max. Range 1.2 - 1.6	1.40	1.432	0.032	1.6
80-100% Max. Range 1.6 - 2.0	1.85	1.895	0.045	2.25

*Acceptable tolerance is 4%.

The uncertainty of measurement is ± 0.4 " WC. This is based on the reference standard having a TAR (Test Accuracy Ratio) of at least 4:1.

Technician signature:  Date: 1/18/2018

Reviewed by:  Date: 1/19/2018

Temperature Calibration EPA Method 28R, ASTM 2515							
BOOTH:		TEMPERATURE MONITOR TYPE:			EQUIPMENT NUMBER:		
E1		National Instruments Logger			00335, 00336		
REFERENCE METER EQUIPMENT NUMBER: 00373				Calibration Due Date: 7 /17/18			
CALIBRATION PERFORMED BY:		DATE:		AMBIENT TEMPERATURE:		BAROMETRIC PRESSURE:	
B. Davis		1/17/2018		68		29.87	
Input Temperature (F)	Ambient	Meter A					FB Interior
			Meter B	Filter A	Filter B	Tunnel	
0	1	0	0	1	0	0	0
100	101	100	100	100	100	100	100
300	300	300	300	300	300	300	299
500	500	500	500	500	500	500	499
700	700	700	700	700	700	700	699
1000	1000	1000	1000	1000	1000	1000	1000

Input (F)	FB Top	FB Bottom	FB Back	FB Left	FB Right	Imp A	Imp B	Cat	Stack
0	0	0	0	-1	-1	0	0	0	0
100	100	100	100	99	99	100	100	100	100
300	300	299	299	299	299	300	300	300	299
500	499	499	499	499	499	500	500	500	500
700	699	699	699	699	699	700	700	700	700
1000	1000	999	1000	1000	999	1000	1000	1000	1000

1500
2000

1500
1999

Technician signature: BD Date: 1/17/2018

Reviewed By: [Signature] Date: 1/19/2018

Thermal Metering System Calibration Y Factor

Manufacturer: APEX
 Model: XC-60-EP
 Serial Number: 606002
 OMNI Tracking No.: OMNI-00336
 Calibrated Orifice: Yes

Date	7/18/2017	Acceptable Deviation (5%)	Deviation
y Factor	0.984	0.0492	0.005
Acceptance	Acceptable		

Average Gas Meter y Factor 0.979
--

Orifice Meter dH@ N/A

Calibration Date: 01/17/18
 Calibrated by: B. Davis
 Calibration Frequency: Six months
 Next Calibration Due: 1/18/2018
 Instrument Range: 1.000 cfm
 Standard Temp.: 68 oF
 Standard Press.: 29.92 "Hg
 Barometric Press., Pb: 29.94 "Hg
 Signature/Date: *B. Davis* 1/17/2018

Acceptable y Deviation	0.020
Maximum y Deviation	0.003
Acceptable dH@ Deviation	N/A
Maximum dH@ Deviation	N/A
Acceptance	Acceptable

Standard	Model	Standard Test Meter
Calibrator	S/N	<u>OMNI-00001</u>
	Calib. Date	<u>30-Oct-17</u>
	Calib. Value	<u>0.9977</u> y factor (ref)

B. Davis
1/19/2017

Calibration Parameters	Run 1	Run 2	Run 3
Reference Meter Pressure ("H2O), Pr	0.00	0.00	0.00
DGM Pressure ("H2O), Pd	1.95	1.20	0.80
Initial Reference Meter	223.4	231.9	238
Final Reference Meter	231.7	237.9	243.503
Initial DGM	0	0	0
Final DGM	8.517	6.215	5.713
Temp. Ref. Meter (°F), Tr	68.0	69.1	68.6
Temperature DGM (°F), Td	76.0	78.0	79.0
Time (min)	39.8	36.5	37.0
Net Volume Ref. Meter, Vr	8.300	6.000	5.503
Net Volume DGM, Vd	8.517	6.215	5.713
Gas Meter y Factor =	0.982	0.977	0.978
Gas Meter y Factor Deviation (from avg.)	0.003	0.002	0.001
Orifice dH@	N/A	N/A	N/A
Orifice dH@ Deviation (from avg.)	N/A	N/A	N/A

where:

1. Deviation = |Average value for all runs - current run value|
- ** 2. $y = [Vr \times (y \text{ factor (ref)}) \times (Pb + (Pr / 13.6)) \times (Td + 460)] / [Vd \times (Pb + (Pd / 13.6)) \times (Tr + 460)]$
- ** 3. $dH@ = 0.0317 \times Pd / (Pb (Td + 460)) \times [(Tr + 460) \times \text{time}] / Vr^2$

* Reference calibration is traceable to NIST through NIST Test # 40674, Kimble ASTM E1272, or NIST traceable laboratory

** Equations come from EPA Method 5

The uncertainty of measurement is $\pm 0.14 \text{ ft}^3/\text{min}$. This is based on the reference standard having a TAR (Test Accuracy Ratio) of at least 4:1.

DIFFERENTIAL PRESSURE GAUGE CALIBRATION DATA SHEET

Instrument to be calibrated: Pressure Transducer

Maximum Range: 0-2" WC ID Number: OMNI-00336

Calibration Instrument: Digital Manometer ID Number: OMNI-00395

Date: 1/17/2018 By: B. Davis

This form is to be used only in conjunction with Standard Procedure C-SPC.

Range of Calibration Point ("WC)	Digital Manometer Input ("WC)	Pressure Gauge Response ("WC)	Difference (Input - Response)	% Error of Full Span*
0-20% Max. Range 0 - 0.4	0.35	0.362	0.012	0.6
20-40% Max. Range 0.4 - 0.8	0.65	0.672	0.022	1.1
40-60% Max. Range 0.8 - 1.2	1.00	1.024	0.024	1.2
60-80% Max. Range 1.2 - 1.6	1.30	1.340	0.040	2.0
80-100% Max. Range 1.6 - 2.0	1.70	1.749	0.049	2.45

*Acceptable tolerance is 4%.

The uncertainty of measurement is ± 0.4 " WC. This is based on the reference standard having a TAR (Test Accuracy Ratio) of at least 4:1.

Technician signature:  Date: 1/18/2018

Reviewed by:  Date: 1/19/2018

Temperature Calibration EPA Method 28R, ASTM 2515							
BOOTH:		TEMPERATURE MONITOR TYPE:			EQUIPMENT NUMBER:		
E1		National Instruments Logger			00335, 00336		
REFERENCE METER EQUIPMENT NUMBER: 00373				Calibration Due Date: 7 /17/18			
CALIBRATION PERFORMED BY:		DATE:		AMBIENT TEMPERATURE:		BAROMETRIC PRESSURE:	
B. Davis		1/17/2018		68		29.87	
Input Temperature (F)	Ambient	Meter A					FB Interior
			Meter B	Filter A	Filter B	Tunnel	
0	1	0	0	1	0	0	0
100	101	100	100	100	100	100	100
300	300	300	300	300	300	300	299
500	500	500	500	500	500	500	499
700	700	700	700	700	700	700	699
1000	1000	1000	1000	1000	1000	1000	1000

Input (F)	FB Top	FB Bottom	FB Back	FB Left	FB Right	Imp A	Imp B	Cat	Stack
0	0	0	0	-1	-1	0	0	0	0
100	100	100	100	99	99	100	100	100	100
300	300	299	299	299	299	300	300	300	299
500	499	499	499	499	499	500	500	500	500
700	699	699	699	699	699	700	700	700	700
1000	1000	999	1000	1000	999	1000	1000	1000	1000

1500
2000

1500
1999

Technician signature: BD Date: 1/17/2018

Reviewed By: [Signature] Date: 1/19/2018

Certificate of Calibration

Certificate Number: **659360**



JJ Calibrations, Inc.

7007 SE Lake Rd
Portland, OR 97267-2105
Phone 503.786.3005
FAX 503.786.2994

Omni-Test Laboratories
13327 NE Airport Way
Portland, OR 97230

PO: **170149**
Order Date: **09/22/2017**
Authorized By: **N/A**



Property #: **OMNI-00410**
User: **N/A**
Department: **N/A**
Make: **Dwyer**
Model: **1430**
Serial #: **OMNI-00410**
Description: **Microtector**
Procedure: **SEND TO VENDOR**
Accuracy: **±0.00025" WC**

Calibrated on: **10/11/2017**
*Recommended Due: **10/11/2018**
Environment: **19 °C 52 % RH**
* As Received: **Limited**
* As Returned: **Limited**
Action Taken: **Calibrated**
Technician: **34**

Remarks: * Many factors may cause the unit to drift out of calibration before the recommended due date. Any reported error is the absolute value between the reference and the unit. Uncertainties include the effects of the unit.

Limited Calibration (est.2016) - Calibrated micrometer head only.

Standards Used

Std ID	Manufacturer	Model	Nomenclature	Due Date	Trace ID
541A	Select	E8FED2	8 Piece Gage Block Set	12/14/2017	635720
103A	Brown & Sharpe	598-81-14	Gage Block Set, 81 pc.	03/16/2019	643452
368A	Rutland	2225-7081	81 Piece Gage Block Set	06/01/2018	649394

Measurement Data

Parameter	Measurement Description	Range Unit	Reference	Min	Max	Error	UUT	Uncertainty
Before/After								
Length								Accredited = ✓
		Inch	0.1300	0.129	0.131	0.000	0.130 Inch	1.1E-03 ✓
		Inch	0.3850	0.384	0.386	0.000	0.385 Inch	1.1E-03 ✓
		Inch	0.6150	0.614	0.616	0.000	0.615 Inch	1.1E-03 ✓
		Inch	0.8700	0.869	0.871	0.000	0.870 Inch	1.1E-03 ✓
		Inch	1.0000	0.999	1.001	0.000	1.000 Inch	1.1E-03 ✓

JJ Calibrations, Inc. certifies that this instrument has been calibrated in accordance with the JJ Calibrations Quality Assurance Manual with the stated procedure using standards that are traceable to the National Institute of Standards and Technology (NIST), or other National Measurement Institutes (NMI's), or by using natural physical constants, intrinsic standards or ratio calibration techniques. The quality system and this certificate are in compliance with ANSI/NCCL Z540-1-1994, ISO/IEC 17025-2005, ISO 10012-1, the ISO 9000 family and QS 9000. The expanded uncertainties of measurements for this calibration are based upon 95% (2 sigma) confidence limits. Unless otherwise stated, a test accuracy ratio (TAR) of 4:1, if achievable, is maintained. The results reported herein apply only to the calibration of the item described above. This report may not be reproduced, except in full, without prior written consent of JJ Calibrations, Inc.
JJ Calibrations, Inc. quality system has been assessed and accredited to ISO/IEC 17025:2005.

Reviewer

3 Issued 10/13/2017 Rev # 15

Inspector

VWR Temperature Hygrometer Calibration Procedure and Data Sheet

Frequency: Every Two Years

Step 1: Locate NIST traceable standard.

Step 2: Place unit to be calibrated, tracking No. OMNI-00592, inside OMNI desiccate box on the same shelf with the NIST traceable standard.

Step 3: After a period of not less than four hours record the temperature and humidity of both units in the spaces provide below.

Step 4: If the unit to be calibrated matches the NIST standard within $\pm 4\%$, it is acceptable. If not, the unit needs to be sent to a repair company or replaced.

Verification Data:

Date: 1/8/2018 Technician: B Davis

Time in desiccate: 0910 Recording time: 1335

NIST Standard Temperature: 28.3 °F NIST Standard Humidity: 74.5

Test Unit Temperature Reading: 25.4 °F Test Unit Humidity Reading: 74.3

Test unit OMNI- 00592 is X or was not within acceptable limits.

Technician Signature: B Davis

Comments: Full scale of OMNI-00592 is 90% RH, with a difference of 2.9 this gives a error percentage of 3.22%. This value is within the allowable 4%.

OMNI Track #	OMNI-00594			
Equipment Name/Description	CAI ZRE-4 Gas Analyzer			
Equipment S/N:	N5F0112			
Comments	CO2, O2, and dual range CO gas analyzer.			
Status	Active, calibrate prior to use.			
Part #	ZRE-4			
Reference Standard:	<input type="checkbox"/> YES	<input checked="" type="checkbox"/> X	<input type="checkbox"/> NO	(Check 'X' for answer)
Location of Equipment:	Portable gas cart.			
Calibration Vendor	OMNI in house			
Type of Calibration	Calibrate Prior to use.			
Calibration Period (Months)	N/A			
Date of Last Calibration	N/A			
Date of Next Calibration	N/A			

Do the following:

- 1) Complete Calibration documentation
- 2) Complete top half of this form
- 3) Attach appropriate calibration forms and save in following location
 \\omni-serv\Test Equipment\Equipment\OMNI-XXXXX - Equipment Name
- 4) Repopulate database with updated information
- 5) Print, laminate and adhere calibration tag to equipment

<p>Verify before use OMNI-00594 Gas Analyzer</p>
--

<p>Verify before use OMNI-00594 Gas Analyzer</p>
--

Certificate of Calibration

Certificate Number: **668066**

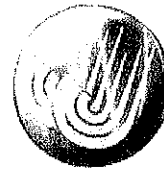

JJ Calibrations, Inc.
 7007 SE Lake Rd
 Portland, OR 97267-2105
 Phone 503.786.3005
 FAX 503.786.2994

Omni-Test Laboratories
 13327 NE Airport Way
 Portland, OR 97230

OnSite

PO: **180161**
 Order Date: **02/06/2018**
 Authorized By: **N/A**



Calibrated on: **02/06/2018**
 *Recommended Due: **08/06/2018**
 Environment: **20 °C 53 % RH**
 * As Received: **Within Tolerance**
 * As Returned: **Within Tolerance**
 Action Taken: **Calibrated**
 Technician: **111**

Property #: **OMNI-00637**
 User: **N/A**
 Department: **N/A**
 Make: **Mettler Toledo**
 Model: **MS104TS/00**
 Serial #: **B729400181**
 Description: **Analytical Scale, 120g**
 Procedure: **DCN 500887**
 Accuracy: **±0.0005g**

Remarks: * Many factors may cause the unit to drift out of calibration before the recommended due date. Any reported error is the absolute value between the reference and the unit. Uncertainties include the effects of the unit.

Standards Used

Std ID	Manufacturer	Model	Nomenclature	Due Date	Trace ID
503A	Rice Lake	1mg-200g (Class 0)	Mass Set,	04/20/2018	642578

Measurement Data

Parameter	Measurement Description	Range Unit	Reference	Min	Max	*Error	UUT	Uncertainty
Before/After	Force							Accredited = ✓
		g	10.00000	9.9995	10.0005	0.0001	10.0001 g	5.7E-04 ✓
		g	30.00000	29.9995	30.0005	0.0003	30.0003 g	5.7E-04 ✓
		g	60.00000	59.9995	60.0005	0.0001	60.0001 g	5.7E-04 ✓
		g	90.00000	89.9995	90.0005	0.0001	89.9999 g	5.7E-04 ✓
		g	120.00000	119.9995	120.0005	0.0002	119.9998 g	5.7E-04 ✓

JJ Calibrations, Inc. certifies that this instrument has been calibrated in accordance with the JJ Calibrations Quality Assurance Manual with the stated procedure using standards that are traceable to the National Institute of Standards and Technology (NIST), or other National Measurement Institutes (NMI's), or by using natural physical constants, intrinsic standards or ratio calibration techniques. The quality system and this certificate are in compliance with ANSI/NCSL Z540-1-1994, ISO/IEC 17025-2005, ISO 10012-1, the ISO 9000 family and QS 9000. The expanded uncertainties of measurements for this calibration are based upon 95% (2 sigma) confidence limits. Unless otherwise stated, a test accuracy ratio (TAR) of 4:1, if achievable, is maintained. The results reported herein apply only to the calibration of the item described above. This report may not be reproduced, except in full, without prior written consent of JJ Calibrations, Inc.
 JJ Calibrations, Inc. quality system has been assessed and accredited to ISO/IEC 17025:2005.

[Signature]
 Reviewer

3 Issued

Rev # 15

Inspector

*Model: PP70
Hearth & Home Technologies
352 Mountain House Road
Halifax, PA 17032*

Example Calculations

Equations and Sample Calculations – ASTM E2779 & E2515

Manufacturer: Hearth & Home
 Model: PP70
 Run: 1
 Category: [Integrated]

Equations used to calculate the parameters listed below are described in this appendix. Sample calculations are provided for each equation. The raw data and printout results from a sample run are also provided for comparison to the sample calculations.

M_{Bdb} – Weight of test fuel burned during test run, dry basis, kg

M_{BSidb} – Weight of test fuel burned during test run segment i , dry basis, kg

BR – Average dry burn rate over full integrated test run, kg/hr

BR_{Si} – Average dry burn rate over test run segment i , kg/hr

V_s – Average gas velocity

Q_{sd} – Average gas flow rate

$V_{m(std)}$ – Volume of Gas S Volume of gas sampled corrected to standard conditions, dscf

m_n – Total Particulate Ma Average dilution tunnel gas velocity, ft/sec

C_s - Concentration of part Particulate concentration, g/dscf

E_T – Total Particulate Err Dilution tunnel gas flow rate, dscf/min

PR - Proportional Rate V_s Particulate emission rate, lbs/hr

PM_R – Average particulat Total particulate emissions, grams

PM_F – Average particulat Average fuel load moisture content, %

M_{Bdb} – Weight of test fuel burned during test run, dry basis, kg
ASTM E2779 equation (1)

$$M_{Bdb} = (M_{Swb} - M_{Ewb})(100/(100 + FM))$$

Where,

- FM = average fuel moisture of test fuel, % dry basis
- M_{Swb} = weight of test fuel in hopper at start of test run, wet basis, kg
- M_{Ewb} = weight of test fuel in hopper at end of test run, wet basis, kg

Sample Calculation:

5.9 %

$M_{Swb} = 41.5$ lbs

$M_{Ewb} = 28.5$ lbs

0.4536 = Conversion factor from lbs to kg

$$M_{Bdb} = [(41.5 \times 0.4536) - (28.5 \times 0.4536)] (100/(100 + 5.91))$$

$M_{Bdb} = 5.6$ kg

M_{BSidb} – Weight of test fuel burned during test run segment i , dry basis, kg
ASTM E2779 equation (2)

$$M_{BSidb} = (M_{SSiwb} - M_{ESiwb})(100/(100 + FM))$$

Where,

M_{SSiwb} = weight of test fuel in hopper at start of test run segment i , wet basis, kg

M_{ESiwb} = weight of test fuel in hopper at end of test run segment i , wet basis, kg

Sample Calculation (from medium burn rate segment):

$$FM = 5.9 \%$$

$$M_{SSiwb} = 36.4 \text{ lbs}$$

$$M_{ESiwb} = 32.7 \text{ lbs}$$

0.4536 = Conversion factor from lbs to kg

$$M_{BSidb} = [(36.4 \times 0.4536) - (32.7 \times 0.4536)] (100/(100 + 5.9))$$

$$M_{BSidb} = 1.6 \text{ kg}$$

BR – Average dry burn rate over full integrated test run, kg/hr
ASTM E2779 equation (3)

$$BR = \frac{60 M_{Bdb}}{\theta}$$

Where,

θ = Total length of full intergrated test run, min

Sample Calculation:

$$M_{Bdb} = 5.57 \quad \text{kg}$$

$$\theta = 360 \quad \text{min}$$

$$BR = \frac{60 \times 5.57}{360}$$

$$BR = \mathbf{0.93} \quad \text{kg/hr}$$

BR_{Si} – Average dry burn rate over test run segment *i*, kg/hr
ASTM E2779 equation (4)

$$BR_{Si} = \frac{60 M_{BSidb}}{\theta_{Si}}$$

Where,

$$\theta_{Si} = \text{Total length of test run segment } i, \text{ min}$$

Sample Calculation (from medium burn rate segment):

$$M_{BSidb} = 1.58 \text{ kg}$$

$$\theta = 120 \text{ min}$$

$$BR = \frac{60 \times 1.58}{120}$$

$$BR = \mathbf{0.79} \text{ kg/hr}$$

V_s – Average gas velocity in the dilution tunnel, ft/sec

ASTM E2515 equations (9)

$$V_s = F_p \times K_p \times C_p \times (\sqrt{\Delta P})_{avg} \times \sqrt{\frac{T_s}{P_s \times M_s}}$$

Where:

- F_p = Adjustment factor for center of tunnel pitot tube placement, $F_p = \frac{V_{strav}}{V_{scent}}$, ASTM E2515 Equation (1)
- V_{scent} = Dilution tunnel velocity calculated after the multi-point pitot traverse at the center, ft/sec
- V_{strav} = Dilution tunnel velocity calculated after the multi-point pitot traverse, ft/sec
- k_p = Pitot tube constant, 85.49
- C_p = Pitot tube coefficient: 0.99, unitless
- ΔP* = Velocity pressure in the dilution tunnel, in H₂O
- T_s = Absolute average gas temperature in the dilution tunnel, °R; (°R = °F + 460)
- P_s = Absolute average gas static pressure in dilution tunnel, = P_{bar} + P_g, in Hg
- P_{bar} = Barometric pressure at test site, in. Hg
- P_g = Static pressure of tunnel, in. H₂O; (in Hg = in H₂O/13.6)
- M_s = **The dilution tunnel wet molecular weight; M_s = 28.78 assuming a dry weight of 29 lb/lb-mole

Sample calculation:

$$F_p = \frac{14.33}{15.59} = 0.919$$

$$V_s = 0.919 \times 85.49 \times 0.99 \times 0.241 \times \left(\frac{81.7 + 460}{\left(30.51 + \frac{-0.20}{13.6} \right) \times 28.78} \right)^{1/2}$$

$$V_s = \mathbf{14.73 \text{ ft/s}}$$

*The ASTM test standard mistakenly has the square root of the average delta p instead of the average of the square root of delta p. The current EPA Method 2 is also incorrect. This was verified by Mike Toney at EPA.

**The ASTM test standard mistakenly identifies M_s as the dry molecular weight. It should be the wet molecular weight as indicated in EPA Method 2.

Q_{sd} – Average gas flow rate in dilution tunnel, dscf/hr

ASTM E2515 equation (3)

$$Q_{sd} = 3600 \times (1 - B_{ws}) \times v_s \times A \times \frac{T_{std}}{T_s} \times \frac{P_s}{P_{std}}$$

Where:

- 3600 = Conversion from seconds to hours (ASTM method uses 60 to convert in minutes)
- B_{ws} = Water vapor in gas stream, proportion by volume; assume 2%
- A = Cross sectional area of dilution tunnel, ft²
- T_{std} = Standard absolute temperature, 528 °R
- P_s = Absolute average gas static pressure in dilution tunnel, = P_{bar} + P_g, in Hg
- T_s = Absolute average gas temperature in the dilution tunnel, °R; (°R = °F + 460)
- P_{std} = Standard absolute pressure, 29.92 in Hg

Sample calculation:

$$Q_{sd} = 3600 \times (1 - 0.02) \times 14.73 \times 0.196 \times \frac{528}{81.7 + 460} \times \frac{30.5 + \frac{-0.20}{13.6}}{29.92}$$

Q_{sd} = ##### dscf/hr

$V_{m(std)}$ – Volume of Gas Sampled Corrected to Dry Standard Conditions, dscf
 ASTM E2515 equation (6)

$$V_{m(std)} = K_1 \times V_m \times Y \times \frac{P_{bar} + \left(\frac{\Delta H}{13.6} \right)}{T_m}$$

Where:

- K_1 = 17.64 °R/in. Hg
- V_m = Volume of gas sample measured at the dry gas meter, dcf
- Y = Dry gas meter calibration factor, dimensionless
- P_{bar} = Barometric pressure at the testing site, in. Hg
- ΔH = Average pressure differential across the orifice meter, in. H₂O
- T_m = Absolute average dry gas meter temperature, °R

Sample Calculation:

Using equation for Train 1:

$$V_{m(std)} = 17.64 \times 59.062 \times 0.977 \times \frac{\left(30.51 + \frac{1.33}{13.6} \right)}{\left(82.2 + 460 \right)}$$

$$V_{m(std)} = \mathbf{57.456} \text{ dscf}$$

Using equation for Train 2:

$$V_{m(std)} = 17.64 \times 57.071 \times 0.979 \times \frac{\left(30.51 + \frac{1.04}{13.6} \right)}{\left(82.5 + 460 \right)}$$

$$V_{m(std)} = \mathbf{55.560} \text{ dscf}$$

Using equation for ambient train:

$$V_{m(std)} = 17.64 \times 55.10 \times 0.997 \times \frac{\left(30.51 + \frac{0.00}{13.6} \right)}{\left(73.3 + 460 \right)}$$

$$V_{m(std)} = \mathbf{55.430} \text{ dscf}$$

m_n – Total Particulate Matter Collected, mg

ASTM E2515 Equation (12)

$$m_n = m_p + m_f + m_g$$

Where:

m_p = mass of particulate matter from probe, mg

m_f = mass of particulate matter from filters, mg

m_g = mass of particulate matter from filter seals, mg

Sample Calculation:

Using equation for Train 1 (first hour):

$$m_n = 0.0 + 0.9 + 0.0$$

$$m_n = 0.9 \text{ mg}$$

Using equation for Train 1 (remainder):

$$m_n = 0.0 + 1.5 + 0.3$$

$$m_n = 1.8 \text{ mg}$$

Train 1 Aggregate = **2.7 mg**

Using equation for Train 2:

$$m_n = 0.0 + 2.8 + 0.0$$

$$m_n = \mathbf{2.8 \text{ mg}}$$

C_s - Concentration of particulate matter in tunnel gas, dry basis, corrected to standard conditions, g/dsc
ASTM E2515 equation (13)

$$C_s = K_2 \times \frac{m_n}{V_{m(\text{std})}}$$

Where:

K₂ = Constant, 0.001 g/mg

m_n = Total mass of particulate matter collected in the sampling train, mg

V_{m(std)} = Volume of gas sampled corrected to dry standard conditions, dscf

Sample calculation:

For Train 1:

$$C_s = 0.001 \times \frac{2.7}{57.46}$$

$$C_s = \mathbf{0.00005} \text{ g/dscf}$$

For Train 2

$$C_s = 0.001 \times \frac{2.8}{55.56}$$

$$C_s = \mathbf{0.00005} \text{ g/dscf}$$

For Ambient Train

$$C_r = 0.001 \times \frac{0.0}{55.43}$$

$$C_r = \mathbf{0.000000} \text{ g/dscf}$$

E_T – Total Particulate Emissions, g

ASTM E2515 equation (15)

$$E_T = (C_s - C_r) \times Q_{std} \times \theta$$

Where:

- C_s = Concentration of particulate matter in tunnel gas, g/dscf
- C_r = Concentration particulate matter room air, g/dscf
- Q_{std} = Average dilution tunnel gas flow rate, dscf/hr
- θ = Total time of test run, minutes

Sample calculation:

For Train 1

$$E_T = (\underline{0.000047} - 0.000000) \times \underline{\hspace{1cm}} \times \underline{360} /60$$
$$E_T = \underline{2.86} \text{ g}$$

For Train 2

$$E_T = (\underline{0.000050} - 0.000000) \times \underline{\hspace{1cm}} \times \underline{360} /60$$
$$E_T = \underline{3.06} \text{ g}$$

Average

$$E = \underline{2.96} \text{ g}$$

Total emission values shall not differ by more than 7.5% from the total average emissions

$$7.5\% \text{ of the average} = \underline{0.22}$$

$$\text{Train 1 difference} = \underline{0.10}$$

$$\text{Train 2 difference} = \underline{0.10}$$

PR - Proportional Rate Variation

ASTM E2515 equation (16)

$$PR = \left[\frac{\theta \times V_{mi} \times V_s \times T_m \times T_{si}}{\theta_i \times V_m \times V_{si} \times T_{mi} \times T_s} \right] \times 100$$

Where:

- θ = Total sampling time, min
- θ_i = Length of recording interval, min
- V_{mi} = Volume of gas sample measured by the dry gas meter during the "ith" time interval, dcf
- V_m = Volume of gas sample as measured by dry gas meter, dcf
- V_{si} = Average gas velocity in the dilution tunnel during the "ith" time interval, ft/sec
- V_s = Average gas velocity in the dilution tunnel, ft/sec
- T_{mi} = Absolute average dry gas meter temperature during the "ith" time interval, °R
- T_m = Absolute average dry gas meter temperature, °R
- T_{si} = Absolute average gas temperature in the dilution tunnel during the "ith" time interval, °R
- T_s = Absolute average gas temperature in the dilution tunnel, °R

Sample calculation (for the first 1 minute interval of Train 1):

$$PR = \left(\frac{360 \times 1.615 \times 14.73 \times (93.0 + 460) \times (82.2 + 460)}{10 \times 59.06 \times 14.48 \times (81.7 + 460) \times (75.0 + 460)} \right) \times 100$$

$$PR = \underline{104} \%$$

PM_R – Average particulate emissions for full integrated test run, g/hr
ASTM E2779 equation (5)

$$PM_R = 60 (E_T/\theta)$$

Where,

E_T = Total particulate emissions, grams

θ = Total length of full integrated test run, min

Sample Calculation:

$$E_T (\text{Dual train average}) = 2.96 \text{ g}$$

$$\theta = 360 \text{ min}$$

$$PM_R = 60 \times (2.96 / 360)$$

$$PM_R = \mathbf{0.49} \text{ g/hr}$$

PM_F – Average particulate emission factor for full integrated test run, g/dry kg of fuel burned
ASTM E2779 equation (6)

$$PM_F = E_T / M_{Bdb}$$

Where,

E_T = Total particulate emissions, grams

M_{Bdb} = Weight of test fuel burned during test run, dry basis, kg

Sample Calculation:

$$E_T (\text{Dual train average}) = 2.96 \text{ g}$$

$$M_{Bdb} = 5.57 \text{ kg}$$

$$PM_F = (2.96 / 5.57)$$

$$PM_F = \mathbf{0.53} \text{ g/kg}$$

*Model: PP70
Hearth & Home Technologies
352 Mountain House Road
Halifax, PA 17032*

Section 5

Labeling & Owner's Manual(s)



CAUTION: HOT WHILE IN OPERATION DO NOT TOUCH, KEEP CHILDREN, CLOTHING AND FURNITURE AWAY. CONTACT MAY CAUSE SKIN BURNS. SEE NAMEPLATE AND INSTRUCTIONS.

ATTENTION: CHAUD LORS DE L'OPÉRATION. NE PAS TOUCHER. GARDEZ LES ENFANTS ET LES VÊTEMENTS LOIN DE L'ESPACE DÉSIGNÉ DE L'INSTALLATION. LE CONTACT PEUT CAUSER DES BRÛLURES À LA PEAU. VOIR L'ÉTIQUETTE ET LES INSTRUCTIONS.



Report: 0135PS040S

PP70 Pellet Stove

SERIAL NO. / NUMÉRO DU

HC079 room for 14 x 875' S/N

1.5" x .375 Barcode Label

Listed Solid Fuel Room Heater/Pellet Type. Also suitable for Mobile Home Installation. This appliance has been tested and listed for use in Manufactured Homes in accordance with OAR 814-23-9000 through 814-23-909.

Appareil de chauffage de combustible solide/de type de boulettes. Accepté dans l'installation dans les maisons mobiles. Cet appareil a été testé et enregistré pour l'usage dans les Maisons Mobiles en accord avec OAR 814-23-9000 jusqu'à 814-23-909.

Listado de habitaciones de combustible sólido del calentador / Pellet Tipo. También es adecuado para la instalación de casas móviles. Este aparato ha sido probado y certificado para su uso en casas prefabricadas, de conformidad con OAR 814-23-9000 través de 814-23-909.

PREVENT HOUSE FIRES / PRÉVENTION DES FEUX DE MAISON

Install and use only in accordance with manufacturer's installation and operating instructions. Contact local building or fire officials about restrictions and installations inspection in your area.

WARNING - FOR MOBILE HOMES: Do not install appliance in a sleeping room. An outside combustion air inlet must be provided. The structural integrity of the mobile home floor, ceiling and walls must be maintained. Refer to manufacturer's instructions and local codes for precautions required for passing chimney through a combustible wall or ceiling. Inspect and clean vent system frequently in accordance with manufacturer's instructions. **DO NOT CONNECT THIS UNIT TO A CHIMNEY SERVING ANOTHER APPLIANCE.** Use a 3" or 4" diameter type "L" or "PL" venting system.

Installez et utilisez en accord avec les instructions d'installation et d'opération du fabricant. Contactez le bureau de la construction ou le bureau des incendies au sujet des restrictions et des inspections d'installation dans votre voisinage. Ne pas obstruez l'espace en dessous de l'appareil.

AVIS - Pour Les Maisons Mobiles: Ne pas installer dans une chambre à coucher. Un tuyau extérieur de combustion d'air doit être installé et ne doit pas être obstrué lorsque l'appareil est en usage. La structure intégrale du plancher, du plafond et des murs de la maison mobile doit être maintenue intacte. Référez vous aux instructions du fabricant et des codes locaux pour les précautions requises pour passer une cheminée à travers un mur ou un plafond combustibles, et les compensations maximums. Inspectez et nettoyez la cheminée fréquemment. Ne pas connecter cet appareil à une cheminée servant un autre appareil. Utilisez système de ventilation "L" ou "P" diamètre 76mm ou 102mm

Instale y use únicamente de acuerdo con la instalación del fabricante y las instrucciones de funcionamiento. Póngase en contacto con la construcción o de los bomberos sobre las restricciones y la inspección en nuestra área.

ADVERTENCIA - Para las casas móviles: No instale el aparato en una habitación para dormir. Una entrada de aire de combustión exterior debe ser proporcionada. La integridad estructural de la planta de casas móviles, techos y paredes deben ser mantenidos.

Consulte las instrucciones del fabricante y los códigos locales para la precauciones necesarias para pasar a través de una chimenea de pared o techo combustible. Inspeccione y limpie el sistema de ventilación con frecuencia, de conformidad con las instrucciones del fabricante. **NO conecte esta unidad a UNA CHIMENEA DE SERVICIO otro aparato.** Use un 3" o 4" de diámetro tipo "L" o "PL" sistema de ventilación.

Conforms to ASTM Std E1509-12. Certified to ULC S627-00. Room Heating Pellet Burning Type, (UM) 84-HUD FOR USE ONLY WITH PELLETIZED WOOD FUEL. Do not use any other type of fuel.

Input Rating: 42,535 Btu/s/hr. Electrical Rating: 120 VAC, 60 Hz, Start 2.6 Amps, Run 2.3 AMPS. Route power cord away from unit. Do not route cord under or in front of appliance. Do not obstruct the space beneath the heater.

DANGER: Risk of electrical shock. Disconnect power supply before servicing. Replace glass only with 5mm ceramic. To start, turn dial control to desired setting, the stove will light automatically. To shutdown, turn dial control to off position. For further instruction refer to owner's manual. Keep viewing doors tightly closed during operation.

Conforme à la norme ASTM E1509-12 Std. Certifié à la norme ULC S627-00 Std. Room Heating Pellet Burning Type, (UM) 84-HUD POUR USAGE AVEC LES BOULETTES DE BOIS. N'utiliser aucun autre genre de combustible.

Puissance de Rendement: 42,535 Btu/s/hr. Puissance Électrique: 120 VAC, 60 Hz, Début 2.6 Amps, Courir 2,3 Amps. Éloignez le fil électrique de l'appareil. Ne pas faire passer le fil électrique au dessus ou en dessous de l'appareil. Ne pas bloquer l'espace au dessous de l'appareil.

DANGER: Il y a risque de décharge électrique. Déconnectez le fil électrique de la prise de contact avant le service. Remplacez la vitre seulement avec une vitre céramique de 5 mm disponible chez votre fournisseur. Pour commencer, tourner le cadran de commande au réglage désiré, le poêle s'allume automatiquement. Pour l'arrêt, tourner le cadran de commande en position OFF. Pour des instructions supplémentaires, référez vous au manuel du propriétaire. Gardez la porte d'ouverture et la porte des cendres fermées hermétiquement durant l'opération.

Cumple con la norma ASTM Std E1509-12. Certificado de ULC S627-00 Std, cuarto de la calefacción de pellets Burning Type, (UM), de 84 de HUD PARA USO EXCLUSIVO CON COMBUSTIBLE DE MADERA granulado. No utilice ningún otro tipo de combustible.

Clasificación de entrada: 42,535 BTU / hr. Clasificación eléctrica: 120 VAC, 60 Hz, 2,6 amperios Inicio, Ejecutar 2,3 amperios. Pase el cable de alimentación alejado de la unidad. No encamine el cordón por debajo o por delante del aparato. No obstruya el espacio debajo de la estufa.

PELIGRO: Riesgo de choque eléctrico. Desconecte el suministro eléctrico antes de darle servicio. Reemplace los vidrios sólo con cerámica de 5 mm. Para comenzar, gire el dial de control hasta la posición deseada, la estufa se encenderá automáticamente. Para apagar, gire el dial de control para la posición de apagado. Para obtener más instrucciones, consulte el manual del propietario. Mantenga las puertas de ver bien cerrados durante la operación.

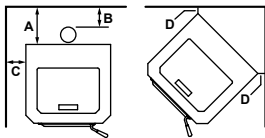

MINIMUM CLEARANCES TO COMBUSTIBLE MATERIALS / ESPACES LIBRES MINIMUM DES MATÉRIAUX DISTANCIAS MÍNIMAS a los materiales combustibles

- A Back Wall / Mur Arrière / Muro Posterior (horizontal installation) 2 in [51 mm]
- B Flue Pipe / Conduit de fumée / Cañon de Humos 3 in [76 mm]
- C Side Wall / Mur De Côté / Muro Lateral 13 in [330 mm]

CORNER INSTALLATION / INSTALLATION DU COIN / RINCÓN DE LA INSTALACIÓN

- D Side Wall / Mur De Côté / Muro Lateral 3 in [76 mm]

FLOOR PROTECTION / PROTECTION DU SOL / PISO DE PROTECCION

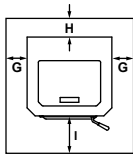

USA
G = 2 in
H* = 2 in
I = 6 in

CANADA
G = 203 mm
H* = 51 mm
I = 152 mm

Floor protector must be non-combustible material, extending beneath heater and to the front/sides/rear as indicated. Measure front distance (I) from the surface of the glass door.

Le poêle doit être placé sur une assise non combustible s'étendant tout autour de lui, comme les schémas l'indiquent. Mesurez la distance du devant (I) de la surface de la porte vitrée.

Protector of piso debe ser de material incombustible, se extiende por debajo del calentador y al frente / lado / trasero, como se indica. Medir la distancia frontal (I) de la superficie de la puerta de vidrio.

*Non-combustible floor protection must extend 2 inches (51mm) beneath the flue pipe when installed with horizontal venting or under the Top Vent Adapter with vertical installation. RECOMMENDED IN USA; REQUIRED IN CANADA.

*Un protecteur incombustible de plancher doit s'étendre 2 inches (51mm) sous le conduit de cheminée pour une installation de ventilation horizontale ou sous un adaptateur de ventilation de dessus pour une installation verticale. RECOMMANDÉ AUX ÉTATS-UNIS; NÉCESSAIRE AU CANADA.

* No es combustible mínimo de protección debe extenderse 2 pulgadas (51mm) por debajo del conducto de humos cuando se instalan con la ventilación horizontal o en el adaptador de ventilación superior con instalación vertical. RECOMENDADO EN EE.UU.; REQUERIDA EN CANADA.

U.S. ENVIRONMENTAL PROTECTION AGENCY
Certified to comply with 2020 particulate emission standards at 0.48 g/hr EPA method 28 and 5G. Not approved for sale after May 15, 2020. This wood heater needs periodic inspection and repair for proper operation. Consult the owner's manual for further information. It is against federal regulations to operate this wood heater in a manner inconsistent with the operating instructions in the owner's manual.

2018	2019	2020	2021	2022	2023	2024	2025	2026	2027	2028	2029	2030
☐	☐	☐	☐	☐	☐	☐	☐	☐	☐	☐	☐	☐

DO NOT REMOVE THIS LABEL / NE PAS ENLEVER L'ÉTIQUETTE

Made in China / Fabriqué en Chine



Hearth & Home Technologies
352 Mountain House Road
Halifax, PA 17032

1.877.427.3316
www.pelprostoves.com



PP70 Pellet Stove

Owner's Manual

⚠ WARNING!

Please read this entire manual before installation and use of this pellet fuel-burning room Stove, and save for future reference. Failure to follow these instructions could result in property damage, bodily injury or even death. Contact local building or fire officials about restrictions and installation inspection requirements in your area.

Note: To obtain a French translation of this manual, please contact your dealer or visit www.pelprostoves.com. Pour obtenir une traduction française de ce manuel, s'il vous plait contacter votre revendeur ou visitez www.pelprostoves.com

Get to Know Your PelPro® Stove

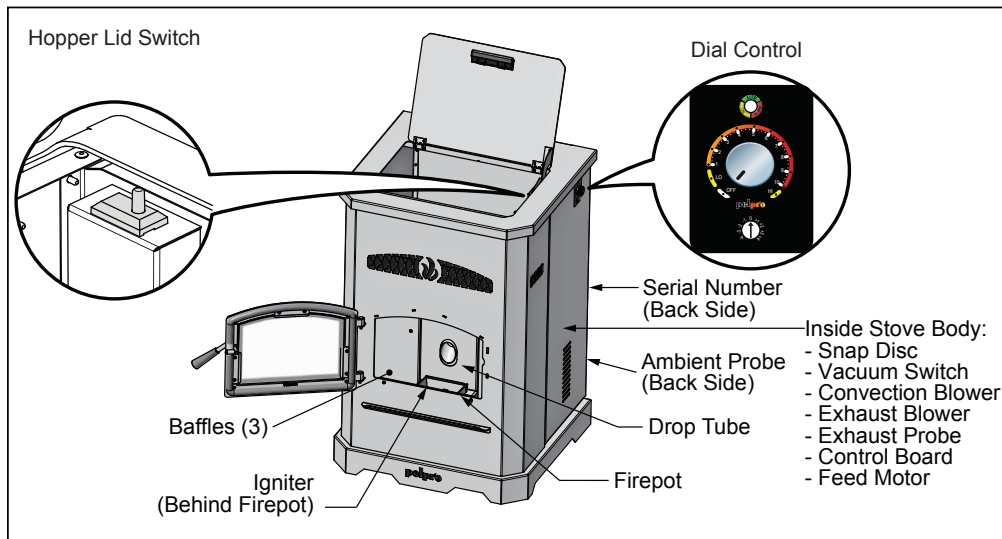

Safety First!

Safety Alert Key: It is important to pay attention to alerts you will see throughout this manual to ensure your safety.

- **DANGER!** Indicates a hazardous situation which, if not avoided will result in death or serious injury.
- **WARNING!** Indicates a hazardous situation which, if not avoided could result in death or serious injury.
- **CAUTION!** Indicates a hazardous situation which, if not avoided, could result in minor or moderate injury.
- **NOTICE:** Indicates practices which may cause damage to the Stove or to property.
- **Pro Tip:** Indicates additional information to help you better understand your Stove and optimize its performance.

NOTICE:

Fire Risk

PelPro disclaims any responsibility, and the warranty and agency listing will be voided, by the below actions.

DO NOT:

- Install or operate damaged Stove
- Modify Stove
- Install other than as instructed by the manufacturer
- Operate the Stove without fully assembling all components
- Over fire (burning at higher temperatures than recommended causing permanent damage to the Stove)
- Install any component not approved by the manufacturer
- Install parts or components not listed or approved
- Disable safety switches

Improper installation, adjustment, alteration, service or maintenance can cause injury or property damage. For assistance or additional information, consult a qualified installer, service agency or your dealer.

DANGER!

HOT SURFACES!

Glass and other surfaces are hot during operation AND cool down.

Hot glass will cause burns.

- Do not touch glass until it is cooled
- NEVER allow children to touch glass
- Keep children away; if you expect that children may come into contact with this Stove, we recommend a barrier such as a decorative screen (see your retailer for suggestions)
- CAREFULLY SUPERVISE children in same room as Stove
- Alert children and adults to hazards of high temperatures

High temperatures may ignite clothing or other flammable materials.

- Keep clothing, furniture, draperies and other flammable materials away



Table of Contents

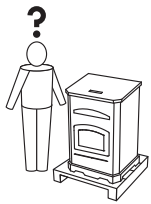

Getting Started..... 4

- Pallet removal
- What's included
- What you'll need



Installing Your Stove 6

- Getting ready
- Placing your Stove
- Venting your Stove



Using Your Stove 13

- Starting your Stove
- What to expect
- Comfort settings
- Turning your Stove off

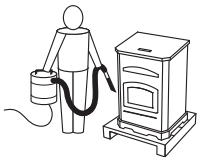

Maintaining Your Stove 20

- What you may need
- Where, when and how



Troubleshooting 24

- Power related
- Blockage related



Support..... 30

- Contact information
- Ordering Parts



Listings and Certifications 31

- Mobile home approval
- Glass specification
- Efficiencies
- Stove dimensions
- Warranty



Reference Materials..... 34

- Service Part List
- Maintenance Log

Getting Started

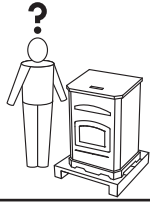

Pallet Removal

There are bolts holding your PelPro Stove in place on the pallet. To remove your Stove from the pallet:



Pallet Removal

Visit pelprostoves.com or scan the code:



1
Loosen the three retaining bolts on the back of the Stove and remove the right and left side panels.

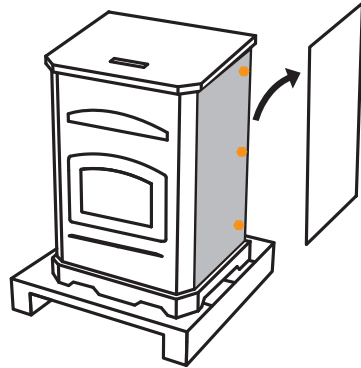

2
Using a 5/16 inch wrench, on each side of the Stove remove the two bolts.

Remove shipping brackets by reaching into Stove in the same area as the just removed bolts.

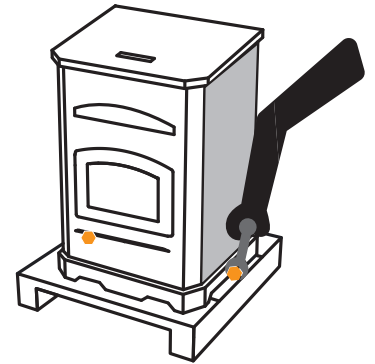

⚠ WARNING!

Inspect Stove and components for damage. Damaged parts may impair safe operation.

- Do NOT install damaged components.
- Do NOT install incomplete components.
- Do NOT install substitute components.

Report damaged parts to dealer.

⚠ CAUTION!

Risk of cuts, abrasions or flying debris. Wear protective gloves & safety glasses during install. Metal edges are sharp.

What's Included



Owner's manual



Cleaning tool



Power cord



Door handle



Online Installation & Troubleshooting Videos

Outside air kit components:



4" Flex hose

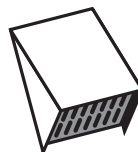

Termination Cap

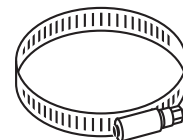

Hose clamp



Screws (4)

74 of 110

Getting Started

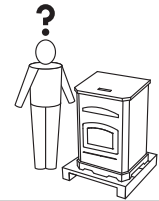

What You'll Need

Tools & Supplies

- High temperature silicone (500°F+)
- Level
- Phillips screwdriver
- Plumb line
- Tape measure
- Framing square
- Reciprocating saw
- Electric drill & bits
- Caulking gun
- Stud finder
- Utility knife
- Pliers
- Flashlight
- Hammer

Safety Equipment

Recommended for all installation and maintenance steps.



Gloves



Safety glasses



Close-toed shoes

Pellet Vent Pipe

Must be an approved 3" or 4" diameter Type "L" or "PL" vent. Use 4" diameter vent if flue height is over 15' or if installation is over 3,000ft. above sea level.



WARNING!

Fire Risk. NO OTHER vent components may be used. Substitute or damaged vent components may impair safe operation.

Floor Protection

Non-combustible material (such as a hearth pad) is required underneath your Stove.

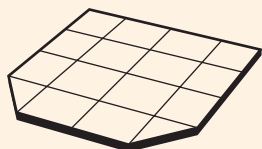

Surge Protector

Protect the electrical components of your Stove by using a surge protector.

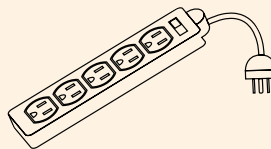

Pellet Fuel

Use only wood pellets in your Stove. For best performance, use premium, low-ash pellets (<1%) less than 1.5" in length and avoid the dusty bits and pieces of pellets in the bottom of the bag.



Installing Your Stove



Getting Ready

Pro Tip

We highly recommend your Stove and pellet vent pipe be installed by a professional installer. Your retailer can make recommendations for you.

Installation **MUST** comply with local, regional, state and national codes and regulations.

Consult insurance carrier, local building inspector, fire officials or authorities having jurisdiction over restrictions, installation inspection and permits.

Placement

Where you place your Stove can significantly affect its performance and safety.

A Your Home Acts Like a Chimney

We recommend that you help your home by:

1. Using a minimum of 5 feet of vertical venting
2. Use the supplied outside air kit
3. Install your Stove on a main floor location

This will:

- Help your Stove breathe
- Minimize smoke leakage in the house
- Enhance performance

B Clearance to Combustibles

The space between your Stove and the items in your home that could burn. Materials such as:

- Wood
- Sheet rock (drywall)
- Carpet

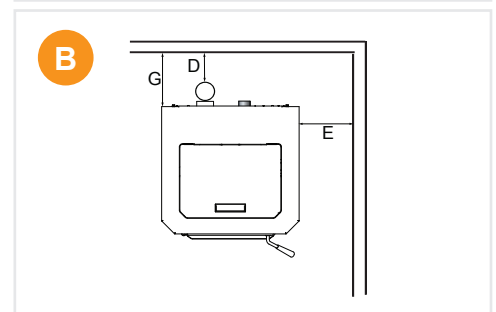
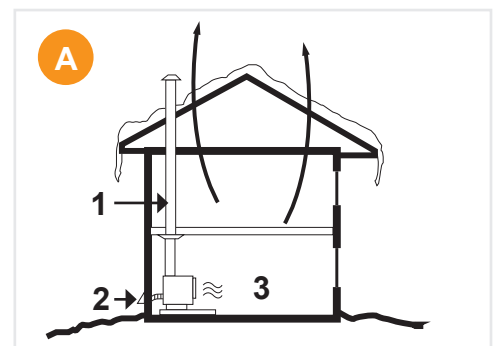

⚠️ WARNING!

Asphyxiation Risk.

DO NOT INSTALL IN A SLEEPING ROOM. Consumes oxygen in the room.

For Canada, the installation must conform to CAN/CSA-B365

Installing Your Stove

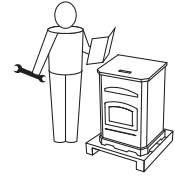

Getting Ready (Continued)

C Pellet Venting

Adding bends in the exhaust path restricts air flow, reduces performance and provides a collection point for ash deposits requiring more frequent cleaning.

⚠ CAUTION

- Do not connect to any air distribution duct or system
- Do not install a flue damper in the exhaust venting system of this Stove
- Do not connect this Stove to a chimney flue serving another Stove
- The structural integrity of the manufactured home floor, wall and ceiling/roof must be maintained

REQUIRED:

Use only 3" or 4" type "L" or "PL" pellet pipe.

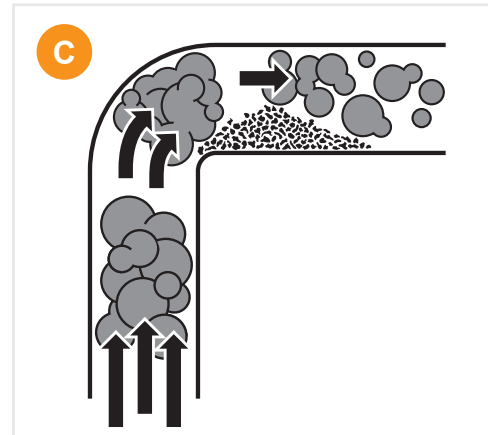

Pro Tip

This Stove can be installed with a 3 to 6 inch (76-152mm) Top Vent Offset Adapter Kit. The 3 to 6 inch (76-152mm) Top Vent Offset Adapter are tested to use 24 gauge single wall flue connector or Listed double wall flue connector to Class A Listed metal chimneys, or masonry chimneys meeting International Conference of Building Officials (ICBO) standards for solid fuel Stoves.

Installation Video



Visit pelprostoves.com or scan this code:



Installing Your Stove

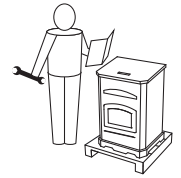

Vent Termination Clearances

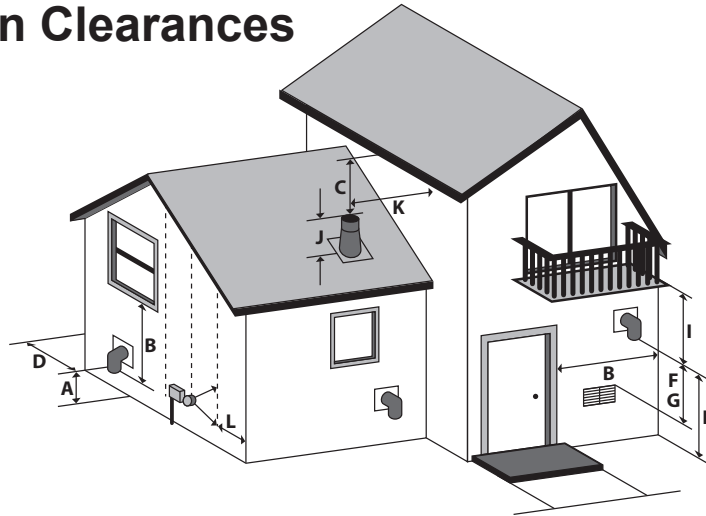

Clearances		
A	12"	Clearance above grade, veranda porch, deck or balcony (Including vegetation and mulch)
B	12"	Clearance beside or below any windows or doors that open
	12"*	Clearance above any window or door that opens
C	18"	Vertical clearance to ventilated soffit located above the terminal within a horizontal distance of 2 feet from the center line of the terminal
D	12"	Clearance to an outside corner wall
F	12", 48" no outside air kit	Clearance to a non-mechanical air supply inlet to the building or a combustion air inlet to any other Stove
G	36"	Clearance to a mechanical air supply inlet
H	84"***	Clearance above a paved sidewalk or paved driveway located on public property
I	12"***	Clearance under a veranda, porch, deck or balcony
J	12"	Clearance above the roof
K	24"	Clearance from an adjacent wall including neighboring buildings
L	36" within a height of 15 feet above the meter / regulator assembly	Clearance to each side of center line extended above natural gas or propane meter / regulator assembly or mechanical vent

*Recommended to prevent condensation on windows and thermal breakage. **This is a recommended distance. For additional requirements check local codes.

NOTICE:

Do NOT terminate vent:

- In any location that will allow flue gases or soot from entering or staining the building
- In any location which could create a nuisance or hazard
- In any enclosed or semi-enclosed area such as a carport, garage, attic, crawl space, under a sun deck or porch or narrow walkway
- Closely fenced area, or any location that can build up a concentration of fumes such as a stairwell, covered breezeway, etc.

NOTICE:

Do NOT terminate below an air inlet.

- It is recommended that at least 60" (1.52m) of vertical pipe be installed when Stove is vented directly through a wall—this will create a natural draft, which will help prevent the possibility of smoke or odor venting into the home during a power outage
- It will also keep exhaust from causing a nuisance or hazard by exposing people or shrubs to high temperatures
- The safest and preferred venting method is to extend the vent vertically through the roof or above the roof

Installing Your Stove

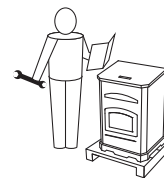

Placing Your Stove

- 1 It is necessary to install **EMBER PROTECTION**; a Type I floor protector for this Stove.

The Floor protector must be non-combustible material, extending beneath Stove with a minimum of 6 inches (152mm) in front of glass and 6 inches (152mm) to both sides of the fuel loading door. Open the door and measure 6 inches (152mm) from the side edge of the opening in the face of the Stove.

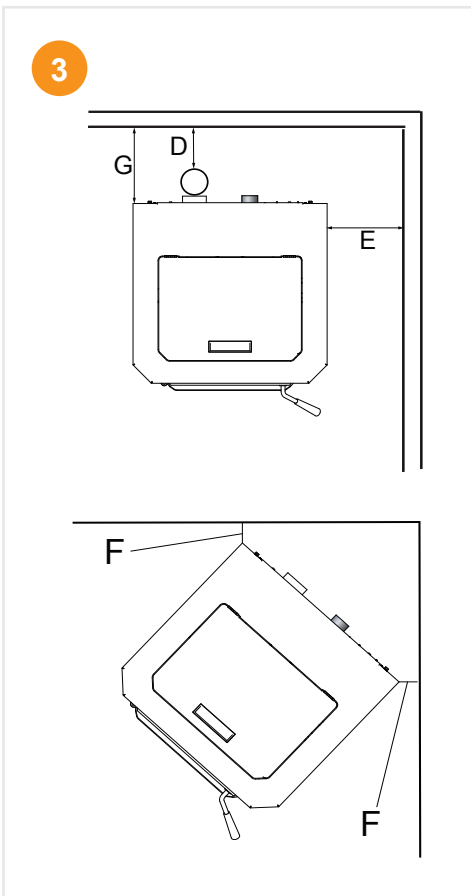
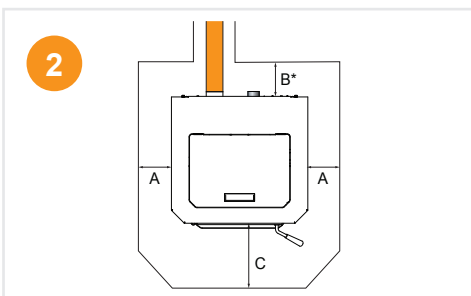
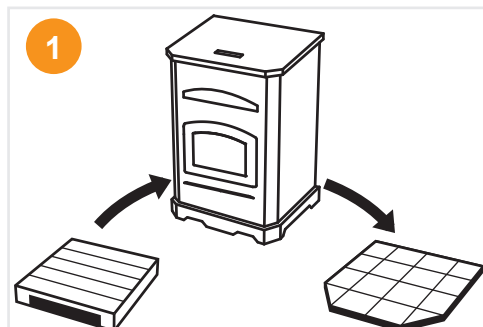

Notice: Be careful to protect the bottom of the Stove and floor surfaces when moving the Stove. Bottom edges of Stove are sharp and can scratch surfaces.

Notice: Clearances may only be reduced by means approved by the regulatory authority having jurisdiction.

- 2 Hearth pad minimum requirements:

USA Hearth Pad Requirements		Inches	mm
A	Sides	2	51
B	Back	2	51
C	Front	6	152

Canada Hearth Pad Requirements		Inches	mm
A	Sides	8	203
B	Back	2	51
C	Front	6	152

Non-combustible floor protection extending beneath the flue pipe is required with horizontal venting or under the top vent adapter with vertical installation.

*Non-combustible floor protection must extend 2 inches (51mm) beneath the flue pipe when installed horizontal venting or under the top vent adapter with vertical installation. CANADA REQUIRED, USA RECOMMENDED.

- 3 Confirm required clearances to combustibles:

Vertical Installations (Interior Flue)			
Straight back against wall		Inches	mm
D	Back wall to pellet pipe	3	254
E	Side wall to Stove	13	330

Corner Installation			
Straight back against wall		Inches	mm
F	Walls to Stove	3	76

Horizontal Installations			
Straight back against wall		Inches	mm
G	Back wall to Stove	2	51
E	Side wall to Stove	13	330

Installing Your Stove



Venting Your Stove

⚠ CAUTION!

Take appropriate precautions to locate utilities within the wall and avoid contact.

- 1 Mark and cut wall for venting penetration on exterior wall (if needed).
- 2 Install wall thimble (sold separately) per manufacturer requirements.
- 3 Install venting. (For additional installation options visit pelprostoves.com)
- 4 Use silicone to create an effective vapor barrier at the location where the chimney or other component penetrates to the exterior of the structure.

Vertical - Interior, Preferred Installation

Exterior - Optional Installations

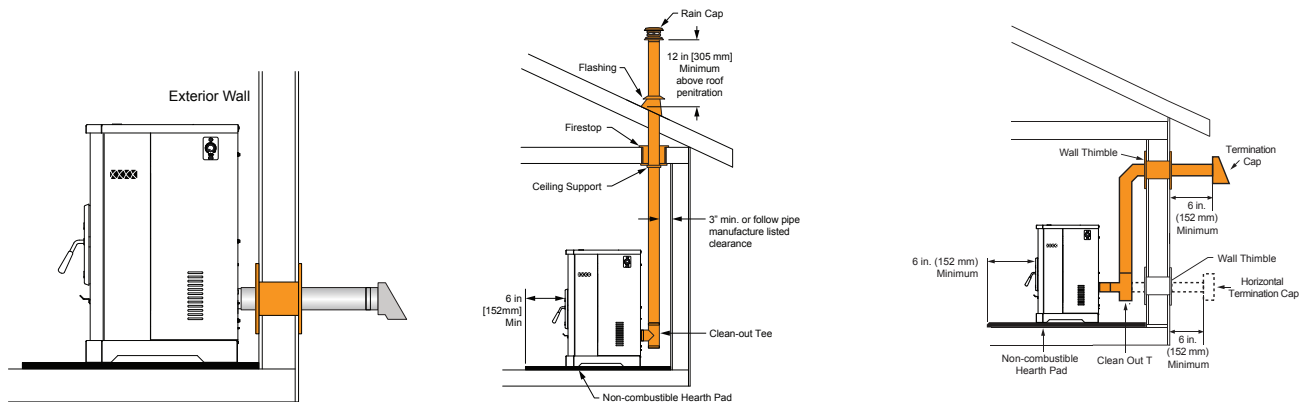

NOTE: In Canada when using a factory-built chimney it must be safety listed, Type UL103 HT (2100°F) CLASS "A" or conforming to CAN/ULC-S629M, STANDARD FOR 650°C FACTORY-BUILT CHIMNEYS.

Pro Tips

- See venting manufacturer's required clearances to combustibles
- For horizontal installations, the minimum clearance from exterior to termination cap is 6"—you may want to increase to 18" clearance to minimize soot blow back on home exterior.

Install vent at clearances specified by the manufacturer

⚠ WARNING!

Do not terminate venting in any enclosed or semi-enclosed area such as: a carport, garage, attic, crawl space, under a sun deck or porch, narrow walkway or closely fenced area, or any location that can build up a concentration of fumes such as a stairwell, covered breezeway, etc.

⚠ CAUTION!

Ensure that your Stove venting terminates above your Stove. The following may occur:

- Your Stove will not draft properly
- Smoke may seep in your house
- Excessive sooting

Installing Your Stove

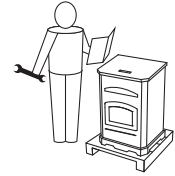

Venting Your Stove

The maximum horizontal venting allowed with no vertical venting attached is 48 inches including one 90° elbow or two 45° elbows. Addition of any horizontal venting beyond 48 inches requires a minimum 60 inches of additional vertical vent. Horizontal sections of vent pipe should have a 1/4 inch rise per foot. We recommend using the shortest venting and fewest elbows possible when venting horizontal.

We recommend the use of 4 inch vent with any installation requiring more than two 90° elbows, or more than 15 feet of venting.

- 45° elbow is equivalent to 1 foot of straight pipe
- 90° elbow is equivalent to 3 feet of straight pipe

⚠ WARNING!
Fire Risk.

- Only LISTED venting components may be used
- NO OTHER vent components may be used. Substitute or damaged vent components may impair safe operation.



Notice:

These are guidelines for successful venting of your pellet Stove. The more vertical rise you can obtain in your system, the better it will perform. Horizontal vent runs can accumulate ash and will need to be cleaned more often. Try to keep them as short as possible.

One 90° Elbow		
Total Horizontal	Minimum Vertical	Vent Diameter
4	0	3
5	5	3
6	6	3
7	7	3
8	8	4
9	9	4
10	10	4
11	11	4
12	12	4
13	13	4
14	14	4
15	15	4
16	16	4
17	17	4
18	18	4
19	19	4

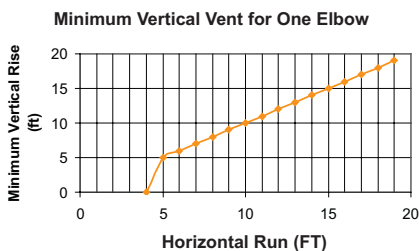

Two 90° Elbows		
Total Horizontal	Minimum Vertical	Vent Diameter
2	5	3
3	6	3
4	7	3
5	8	3
6	9	3
7	10	4
8	11	4
9	12	4
10	13	4
11	14	4
12	15	4
13	16	4
14	17	4
15	18	4

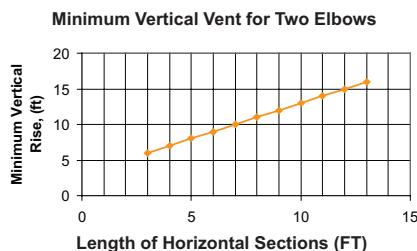

Three 90° Elbows		
Total Horizontal	Minimum Vertical	Vent Diameter
2	11	4
3	12	4
4	13	4
5	14	4
6	15	4
7	16	4
8	17	4
9	18	4
10	19	4
11	20	4

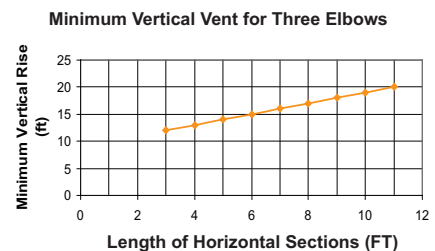

Installing Your Stove



- 5** Install pellet venting through wall and connect vent/pipe to Stove **A**
- Some venting manufacturers offer pellet Stove adapters for their venting for easier installation
 - Seal all pipe joints using high-temp silicone (500°+)
 - Secure exhaust venting system to the Stove with at least 3 screws or rivets per the pipe manufacturer's instructions. Also secure all connector pipe joints with at least 3 screws through each joint.
 - Install termination cap
 - Confirm all required Stove clearances to combustibles

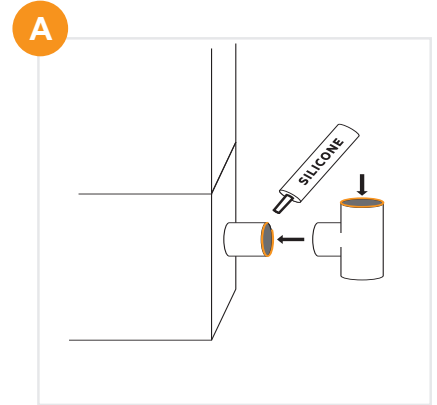

Pro Tip

Installing a clean-out "T" (sold separately) to the rear of your Stove, when venting vertically can save time during cleaning.

- 6** Install outside air kit (included)
- For optimal performance, PelPro recommends the outside air kit for all installations. Outside air kit is required for all mobile/manufactured home installations.

Install through wall **B**

- Maintain clearances from exhaust
- Remove knock out in the rear of Stove
 - Attach flex pipe to outside air connection on Stove
 - Use hose clamp
 - Route tube outside the structure
 - Attach cap
 - Secure to outside wall with appropriate fasteners

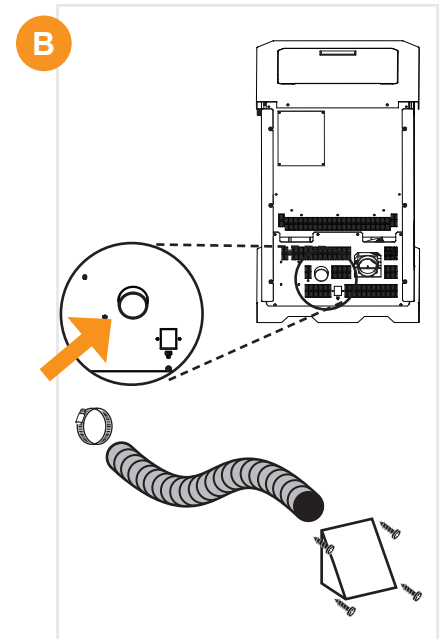

Take a Break

Inspect your work:

- _____ Confirm clearances to combustibles are maintained
- _____ Pipe joints are secure and properly sealed
- _____ Outside air kit installed properly
- _____ Confirm termination clearances



CAUTION!

Never draw outside combustion air from:

- Wall, floor or ceiling cavity
- Enclosed space such as an attic, garage or crawl space.

Using Your Stove



Fuel Tips

Fuel Material and Fuel Storage

Pellet fuel quality can greatly fluctuate. We recommend that you buy fuel in multi-ton lots whenever possible. However, we do recommend trying various brands before purchasing multi-ton lots to ensure your satisfaction. Store fuel in dry location not within clearances to combustibles of your Stove.

Fuel Material

- Made from sawdust or wood by-products
- Depending on the source material it may have a high or low ash content.

Higher Ash Content Material

- Hardwoods with a high mineral content
- Fuel that contains bark
- Standard grade pellets or high ash pellets

Lower Ash Content Material

- Most softwoods
- Fuels with low mineral content
- Most premium grade pellets

Pro Tip

We recommend the use of Pellet Fuels Institute certified pellet fuel with this product.



Your Stove has a manufacture-set minimum low burn rate that must not be altered. It is against federal regulations to alter this setting or otherwise operate your Stove in a manner inconsistent with operation instructions in this manual.

Using Your Stove

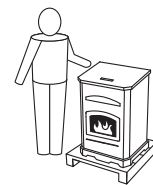

Starting your Stove the first time

What to Expect

- 1 Combustion blower will turn on
- 2 Igniter will turn on
- 3 Pellets will drop, smoke may occur in firebox but will evacuate, and flame will appear in fire pot.
- 4 Convection blower will automatically turn on after the Stove heats up. Convection blower will continue to run even after your Stove has been shut down.

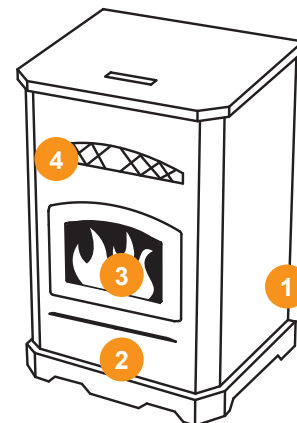

Pro Tips

- Odors and vapors are released during initial startup after purchase; burning your Stove on HI for 30 minutes will allow the paint to cure. Open windows or doors for air circulation until burn off is complete.
- During start up and normal operation your Stove's front door must be closed
- Priming is only required the first time your Stove is lit, or after a FUEL FEED ALARM.



⚠ WARNING!

Fire Risk

Keep combustible materials, gasoline and other flammable vapors and liquids clear of Stove.

- Do NOT operate Stove with door open
- Do NOT operate Stove with fire pot floor open
- Do NOT store flammable materials in the Stove's vicinity
- Do NOT use gasoline, lantern fuel, kerosene, charcoal lighter fluid or similar liquids or gels to start or "freshen up" a fire in this Stove

Keep all such liquids well away from the Stove while it is in use as combustible materials may ignite.



⚠ WARNING!

HOT SURFACES! Glass and other surfaces are hot during operation AND cool down.
Hot glass will cause burns.

- Do not touch glass until it is cooled
- NEVER allow children to touch glass
- Keep children away
- CAREFULLY SUPERVISE children in same room as fireplace
- Alert children and adults to hazards of high temperatures
- High temperatures may ignite clothing or other flammable materials
- Keep clothing, furniture, draperies and other flammable materials away

Using Your Stove

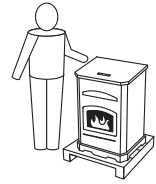

Use and Care

Visit pelprostoves.com or scan this code:



Important:

Allow up to 20 minutes for your Stove to start.

1 Confirm fire pot is properly positioned

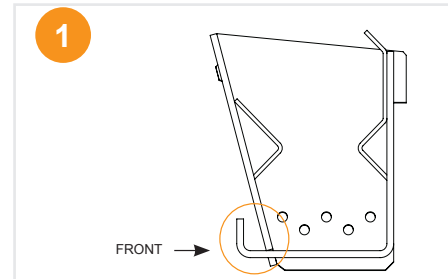

2 Confirm three baffles inside firebox are secure, placing the side baffles before the center

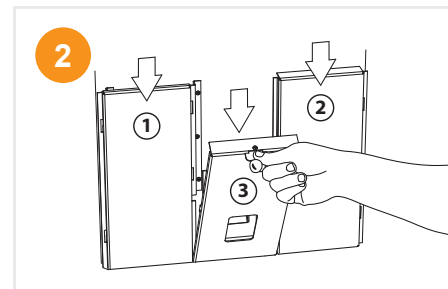

3 Add some pellets to hopper and fully close lid



4 Ensure dial control is set in off position.

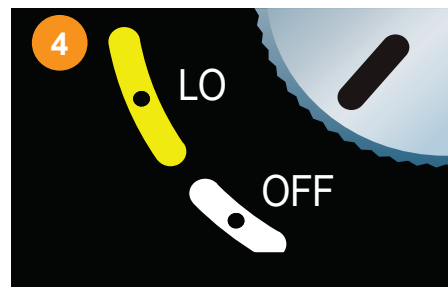

WARNING! Shock hazard.

- Plug directly into properly grounded 3 prong receptacle
- Do NOT route cord under or in front of Stove
- Recommend the use of a surge protector

Using Your Stove



Starting your Stove from an empty hopper

- 5 Plug in your Stove

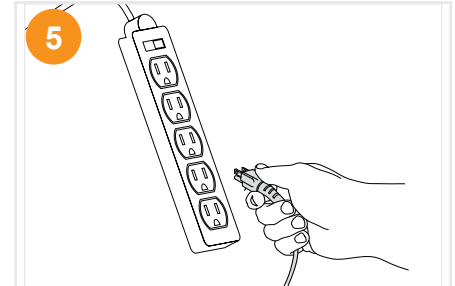

- 6 Wait 1 minute - LED light will start flashing green once per second.



- 7 **Prime your Stove:**
- 1) Quickly turn the dial control from OFF to HI
 - 2) Back to OFF
 - 3) Then back to HI

The feed motor will run continuously for two minutes and the LED light will be solid green. Once primed, pellets will drop into the fire pot and the LED light will blink green as ignition starts. This process can take up to 20 minutes.

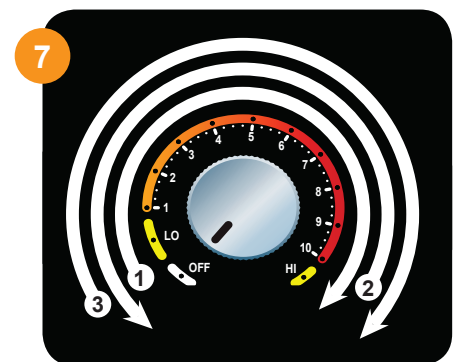

⚠ CAUTION:
During this process DO NOT:
• Try to restart, manually add pellets or use any type of accelerant

Using Your Stove



What Do the Blinking Lights Mean?

Green & Amber - Normal Operation

- Green, Steady On - Feed system is priming
- Green, 1 Blink - Stove is off and ready
- Green, Continuous Blinking - Stove is in the start up/ignition sequence
- Green, Varies Blinks - Varies depending on burn rate
- Amber, Steady On - Stove is set and running at either the minimum or maximum power levels
- Amber, Continuous Blinking - Stove is in the shutdown sequence. *Early models may have a green continuous blinking light during shutdown sequence.

Red - Operational Issue - Refer to troubleshooting

- Red, 1 Blink - Empty hopper, refer to troubleshooting
- Red, 2 Blinks - Exhaust probe alarm, check connections or refer to troubleshooting
- Red, 3 Blinks - Ambient probe alarm, check connections or refer to troubleshooting
- Red, 4 Blinks - Missed ignition, refer to troubleshooting
- Red, 8 Blinks - Exhaust gas over temperature, refer to troubleshooting

If your Stove does not ignite on the initial burn, the LED light will blink red 4 times indicating a missed ignition.

1. Turn your Stove to off, remove and clean the fire pot
2. Confirm fire pot is properly positioned
3. Prime your Stove per previous instructions

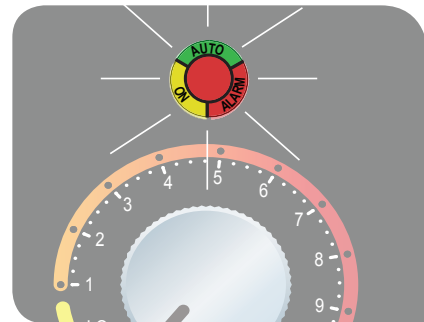

Is this your first start-up after purchase?

If you just bought this Stove, once a fire has been established in your Stove, leave the Stove burning on HI for 30 minutes to allow paint to cure.

After 30 minutes, turn the dial control to OFF and allow your Stove to cool completely. Once cooled, clean the fire pot. Your Stove is now ready to resume normal use.

Using Your Stove

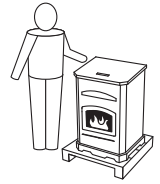

Comfort Settings

Control your comfort with a single dial:

- **OFF setting** - Used to turn your Stove off
- **LO setting** – Your Stove will continue to run on low regardless of room temperature. LED light will be steady amber
- **1 through 10 settings** – Set to your desired comfort level. Once the desired comfort level is achieved the Stove will automatically shut down. When the temperature in the room drops below the desired comfort level, your Stove will automatically restart.
- **HI setting** - Your Stove will continue to run on high regardless of room temperature. LED light will be steady amber.

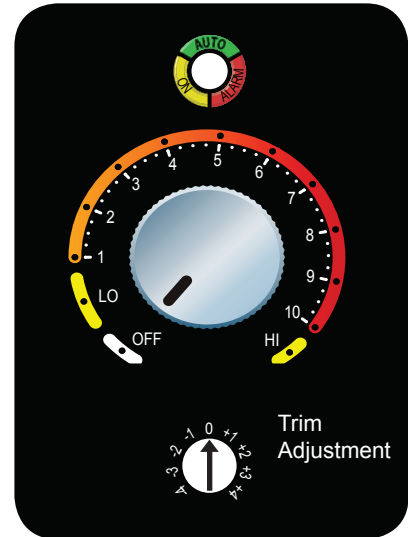

Pro Tip

If the dial control is turned to the off position and then back on, even if by mistake, your Stove will go through the shutdown process (approximately 15 minutes) and restart.

Trim Adjustment

Trim adjustment is the small dial located below the main dial control. Rotating this dial will adjust the air/fuel ratio and below are examples of when to use it:

- If the fire is too large, lazy or producing black soot, rotate the dial counterclockwise one level at a time and allow 15 minutes for stabilization before making another adjustment
- If your fire is too small and sometimes goes out when there are pellets in the hopper, rotate the dial clockwise one level at a time and allow 15 minutes for stabilization before making another adjustment.

Thermostat

Your PelPro Stove comes with a built-in thermostat system that provides easy temperature adjustments. The Stove is not designed to use a remote control or external thermostat.

Using Your Stove



Turning Your Stove Off



1
Turn dial to OFF position

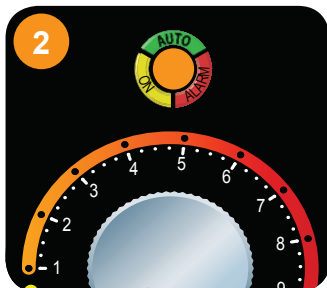

2
LED light will flash amber rapidly *Early models may have a green continuous blinking light during shutdown sequence.



3
Auger stops feeding pellets

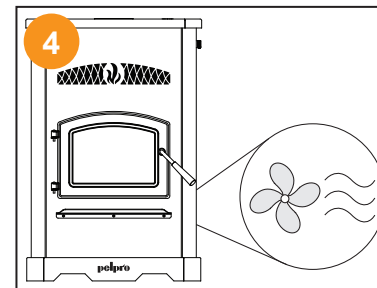

4
Blowers continue to run until after the exhaust temperature has cooled



5
LED light will flash once per second



⚠ CAUTION! Smoke Hazard

- Turn dial control to OFF, let Stove completely cool and exhaust blower must be off. Now you can unplug Stove before servicing
- Smoke spillage into room can occur if Stove is not cool before unplugging

Maintaining Your Stove

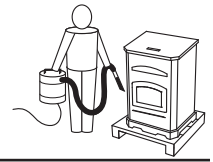

Cleaning & Maintenance

Important:

Regular cleaning helps to assure optimal performance of your Stove. Please refer to page 29 to log your maintenance and cleaning.



Cleaning your Stove

Visit pelprostoves.com or scan this code:



Maintaining your

Stove

Visit pelprostoves.com or scan this code:



What You'll Need



Cleaning tool



Phillips head screwdriver



Safety glasses



Gloves



Ceramic glass cleaner & non-abrasive cloth

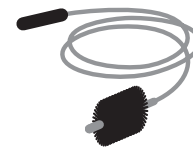

Flue cleaning brush



Metal container with lid



Drop cloth



Ash vacuum

Maintaining Your Stove



Where, When and How

Disposal of Ashes

Ashes should be placed in a metal container with a tight fitting lid. The closed container of ashes should be placed on a non-combustible floor or on the ground, well away from all combustible materials, pending final disposal. If the ashes are disposed of by burial in soil or otherwise locally dispersed, they should be retained in the closed container until all cinders have been thoroughly cooled.



WARNING!

Disconnect Stove from power supply before servicing

Zone 1 - Firebox

WEEKLY OR AS NEEDED

Fire pot

- Remove the fire pot
- Scrape clean and remove ashes
- Replace fire pot

Firebox

- Remove baffles and vacuum residual ash
- Remove ashes from firebox floor

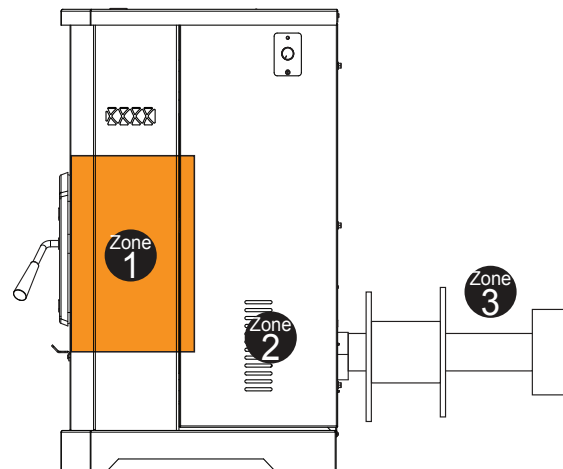

WARNING!

If using a vacuum to clean Stove, be sure embers are thoroughly cooled to prevent a fire in the vacuum.

Glass

- Apply ceramic glass cleaner
- Use non-abrasive cloth to remove residue

Door Inspection

- The gasket between the glass and firebox should be inspected periodically to make sure there is a good seal.

Maintaining Your Stove

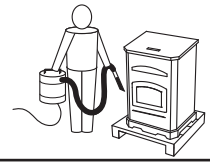

Pro Tip

The type of fuel you are burning will dictate how often you have to clean your fire pot.

If the fuel you are burning has a high dirt or ash content, it may be necessary to clean the fire pot more than once a day.

Poor quality fuel will cause clinkers to form in the fire pot. Clinkers are formed when dirt, ash or a non-burnable substance is heated to 2000 deg. F (1093 deg. C) and becomes glass-like.

Always burn dry fuel. Burning fuel with high moisture content take heat from the fuel and tends to cool the Stove, robbing heat from your home.

Damp pellet fuel can clog the feed system.

⚠ CAUTION!

Handle glass assembly with care and refer to maintenance instructions. **When cleaning glass:**

- Avoid striking, scratching or slamming glass.
- Do NOT clean glass when hot
- Do NOT use abrasive cleaners
- Do NOT operate with glass cracked, broken or scratched



⚠ WARNING!

Glass is 5mm thick high temperature heat resistant ceramic glass.

- DO NOT REPLACE with any other material
- Alternate material may shatter and cause injury

Zone 2 - Stove Body

MONTHLY OR AS NEEDED

Convection Blower

- Remove right and left side panel to access and remove convection blower
- Vacuum any debris from the fan blades and blower housing

Hopper

- Empty hopper of any pellets
- Vacuum any remaining pellets/debris from the hopper

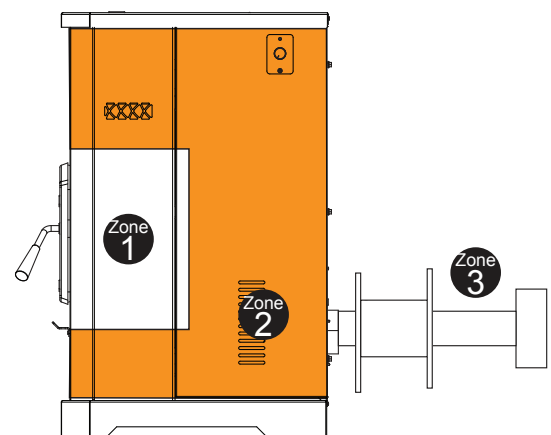

Maintaining Your Stove



Electrical Components

- Identify and remove any debris
- Verify all connections are secure

ANNUALLY OR AS NEEDED

Exhaust Blower

- Remove left side panel to access and remove exhaust blower
- Vacuum any debris from the fan blades and blower housing

Zone 3 - Venting

ANNUALLY OR AS NEEDED

Termination Cap

- Remove termination cap
- Brush out to remove dust and hard buildup

Vent Components

- Soot, creosote, and fly ash will collect in the exhaust venting system and restrict the flow of the flue gases. This build up will occur more quickly in horizontal sections and elbows.
- Use the appropriate sized chimney brush to remove ash and buildup from the venting

Outside Air Kit

- Ensure there are no obstructions in the outside air kit cap

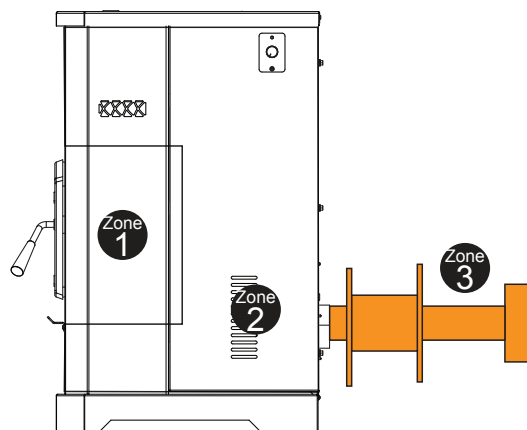

Having Trouble?
Visit the Troubleshooting section of this manual.

Caution!

When wood pellets are burned at a low temperature, they produce organic vapors which combine with moisture to form creosote vapors.

Creosote vapors condense in the relatively cool chimney flue of a newly-started or a low-temperature fire. As a result, creosote residue accumulates on the flue lining. When more heat is called for, this residue can be ignited, which creates an extremely hot fire in the chimney flue; this may damage the chimney or even destroy your home.

Your chimney should be inspected once every few months during the heating season to determine if a creosote or soot buildup has occurred. If creosote or soot has accumulated, it should be removed to reduce the risk of a chimney fire.

Troubleshooting

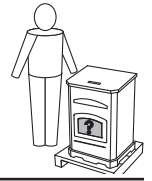

Troubleshooting your Stove

Visit pelprostoves.com or scan the code:



Power Related

⚡ In the event of a power outage:

- If using a generator, PelPro recommends a steady state generator for best Stove performance.
- This Stove needs 110v to run properly. This Stove has not been tested for use with a third party battery backup.

Pro Tip

Check passages to assure they are clear of ash and obstructions. Poor airflow leads to poor performance of your Stove.

⚡ Stove plugged in but no response

- Unplug your Stove
- Check your home's circuit breaker
- Reset snap disc (located between drop tube and hopper (Zone 2) **A**)
- Visually inspect wires, blowers and power cord for breaks or wear to find cause of possible short circuit (Zone 2)

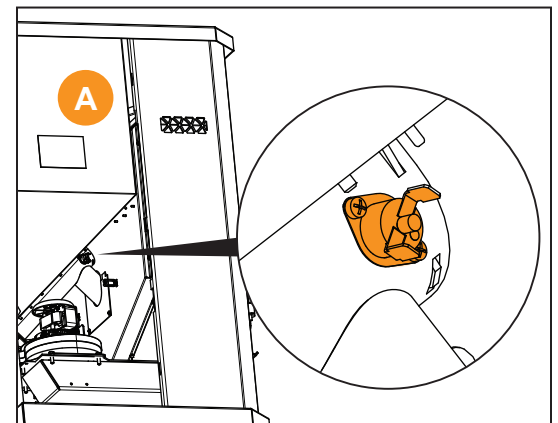

⚡ Component (i.e. blower) fails to start or fails to turn off

- Unplug your Stove
- Check all connections and power plugs are secure
- Visually inspect wires, blowers and power cord to find cause of possible short circuit

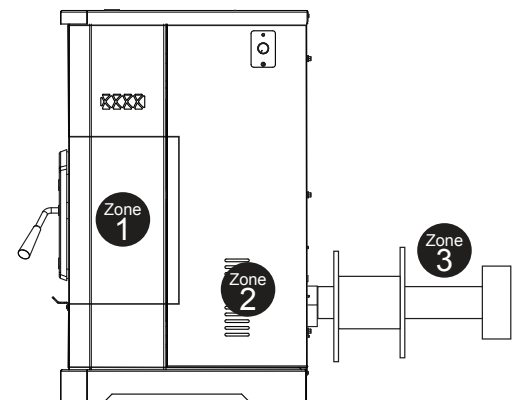

Troubleshooting



Blockage Related

Black soot on outside of house

- Confirm exhaust path is clean and clear (Zone 1 and 3)
 - Adjust air/fuel ratio using trim adjustment dial (See page 23 for trim adjustment instructions)
- Ensure termination cap has at least 18" clearance to reduce the effects of soot blow-back on home exterior (ie. siding)—if not able, refer to page 10 for alternate installation options

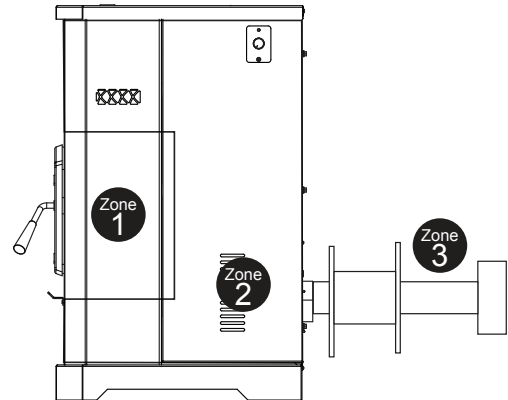

Rumbling/whistling noise during operation

- Confirm exhaust path is clean and clear (Zone 1 & 3)
 - Adjust air/fuel ratio using trim adjustment dial (See page 18 for trim adjustment instructions)

Stove will not light

- Confirm firebox is clean and clear (Zone 1)
 - Igniter is getting hot (glows orange)
- Inspect Stove body (Zone 2)
 - Confirm fuel is in hopper, close lid securely
 - Remove right side panel to access and confirm vacuum switch is clear and connected at both ends
 - Confirm all exhaust blower connections secure
 - Confirm the feed assembly and motor are clean and clear of debris
- Confirm exhaust path is clean and clear (Zone 3)

Troubleshooting

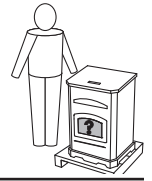

Blockage Related

Fire starts but goes out

- Confirm firebox is clean and clear (Zone 1)
 - Ensure fire pot holes are clear
- Inspect Stove body (Zone 2)
 - Confirm exhaust probe is connected
 - Inspect and clean the exhaust outlet
- Confirm exhaust path is clean and clear (Zone 3)

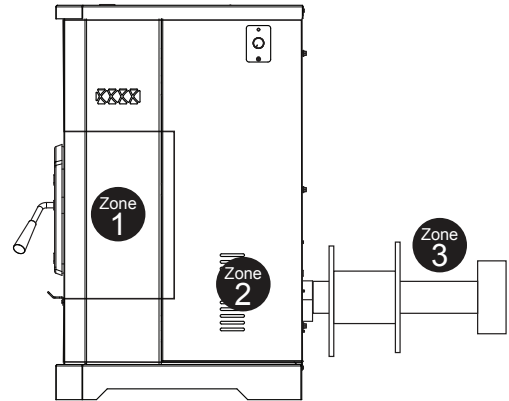

Starts and stops frequently in automatic mode

- Determine if your room is experiencing varying temperatures due to repeated opening/closing of doors or windows—correct if necessary
- Examine Stove body (Zone 2)
 - Inspect ambient probe and confirm that at least 2” is exposed outside of Stove body

Slow or smoky start-up and/or lazy flame

- Confirm exhaust path is clean and clear (Zone 3)
- Examine Stove body (Zone 2)
 - Align igniter so it is properly placed and centered
 - Review fuel quality (see Pellet Fuel information on page 13)

Troubleshooting



Symptom	Possible Cause	Corrective Action
Igniter does not turn off	Igniter short circuit. The fuse will be blown and upon replacement of the fuse, the igniter will remain on when Stove has power.	Inspect wires, blowers, and power cord to find cause of short circuit. Replace board and failed component.
Feed motor does not shut off	Feed motor short circuit. The fuse will be blown and upon replacement of the fuse, the feed motor will remain on when Stove has power.	Open hopper to stop the feed motor. Inspect wires feed motor, control board, and power cord to find source of short circuit. Replace control board and failed component.
Stove fails to shut off.	Stove running in maximum or minimum	Turn dial control to Off position. See Also, "Feed Motor Does Not Shut Off". The Stove should go into a shutdown.
Large, lazy flame, orange color. Black ash on glass.	Dirty Stove. Poor fuel quality, high ash content. Incorrect air-fuel adjustment Excessive feeding/Feed Motor locked on	Clean Stove, including fire pot and venting system. Clean exhaust path. Try a different brand of pellets. Turn fuel adjustment trim dial to COUNTERCLOCKWISE to increase combustion air speed; see trim pot adjustment section. Follow corrective action for feed motor does not turn off symptom.
Excessive fuel spilling over the fire pot into the ash wells and/or excessive flame	Excessive feeding/Feed Motor locked on	Follow corrective action for feed motor does not turn off.

Troubleshooting

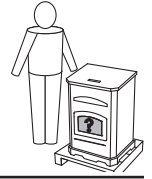

Following correction of any alarm, turn the dial control to the OFF position, wait 10 seconds and turn back to desired setting OR unplug the Stove, wait 10 seconds then restore power.

Alarm (LED Flashing RED)	Possible Cause	Corrective Action
1 Flash: Empty Hopper	<p>No fuel is delivered to the fire pot to sustain flame Hopper empty (most likely) Auger Jam (next likely) No vacuum Hopper lid open</p> <p>Flame is evident but the exhaust probe is not able to recognize the hot exhaust temperature Exhaust probe not attached to outlet Exhaust path is dirty</p>	<p>Fill the hopper, inspect the feed tube for jams, inspect the venting and firebox for obstructions and clean if necessary, inspect the exhaust blower to make sure it runs, or close the hopper lid.</p> <p>Inspect and clean the exhaust outlet, firebox, fire pot, and behind the baffles. Inspect the exhaust probe to see if it is securely attached to the side of the exhaust outlet.</p>
2 Flashes: Exhaust Probe Fail <i>The exhaust probe senses a temperature of less than negative 20 degrees Celsius or above 300 degrees Celsius.</i>	<p>The exhaust temperature is above or below the acceptable range.</p> <p>Exhaust Probe Failure Not plugged in Failed component</p>	<p>Plug the probe into the board Replace the component</p>
3 Flashes: Ambient Probe Alarm <i>The ambient probe senses a temperature of less than negative 20 degrees Celsius or above 70 degrees Celsius.</i>	<p>The ambient temperature is above or below the acceptable range.</p> <p>Ambient Probe Failure Not plugged in Failed component</p>	<p>Plug the probe into the board Replace the component</p>
4 Flashes: Missed Ignition <i>During the ignition sequence the load does not ignite. The Stove will automatically retry once from the first failed attempt.</i>	<p>Fuel No fuel Hopper Empty Feed Jam Feed doesn't turn Feed motor disconnected or failed</p> <p>Fire pot Fire pot Dirty so fuel is not near ignition hole in the fire pot</p> <p>Igniter No power Debris in the end of the igniter chamber</p>	<p>Fill the hopper Inspect and clear jam in the feed tube Inspect the feed motor circuit (hopper lid must be closed, vacuum switch must be closed (ie exhaust blower on), and feed motor must be plugged in.</p> <p>Clean the fire pot</p> <p>Check leads and if the igniter works. Clean the end of the igniter chamber from inside the firebox (removal of the fire pot required for this step).</p>
8 Flashes: Exhaust Over Temperature <i>The exhaust temperature has exceeded the allowable temperature.</i>	<p>Fuel Feed Motor Locked On</p> <p>Non-approved fuel used</p> <p>Convection blower Dirty Failed</p> <p>Installation Installation configuration is tight allowing for limited air circulation around the Stove.</p>	<p>Review the feed motor and feed rates. Normal feed motor operation is on between 1* and 4* seconds out of every 7 seconds. (*depending on model and burn rate setting) If the feed motor does not turn off, replace the control board. Review the fuel being used.</p> <p>Clean Replace</p> <p>Review the installation and move if necessary.</p>

Troubleshooting



? Still having trouble?

Access additional resources at:
pelprostoves.com/troubleshooting



Warranty

 If replacement parts are needed, please note warranty coverage begins on the date of purchase. Retain your original receipt as proof of purchase. The warranty period for covered components is as follows:

Components Covered	Warranty Period (Parts only, Labor not included)
Electrical	1 Year
Steel Parts (excluding fire pot)	5 Years
All replacement parts are covered for remainder of original warranty period or 90 days, whichever is longer	90 Days

Additional terms and limitations apply. See page 28 for complete warranty information.



Please review the “Maintaining Your Stove” and “Troubleshooting” sections in this manual.



Visit **pelprostoves.com** to access:

- Order replacement parts
- Installation videos
- Troubleshooting videos
- Use and care videos
- Manuals and more



To contact a Consumer Care Specialist, email us at **Info_PelPro@hearthnhome.com** or call **877-427-3316**.

Listings and Certifications



Stove Certification

Series	PP70
Laboratory	OMNI Test Laboratories
Safety Report No.	0135PS040S
Type	Solid Fuel Room Stove/Pellet Fuel Burning Type
Standard	ASTM E1509-12 and ULC S627-00, Room Stove Pellet Fuel Burning type and (UM) 84-HUD, Mobile Home Approved.



Note

This installation must conform with local codes.

In the absence of local codes you must comply with **ASTM E1509-12 and ULC S627-00 by OMNI Test Laboratories and (UM) 84-HUD**

⚠️ WARNING!

- It is critical to have a working smoke detector installed in the home of Stove operation.
- Smoke alarms that are properly installed and maintained play a vital role in reducing fire deaths and injuries. Having a working smoke alarm reduces the chance of fire related injuries.
- Install at least one carbon monoxide detector on each floor of your home.



⚠️ WARNING! Asphyxiation Risk.

DO NOT INSTALL IN A SLEEPING ROOM. Your Stove consumes oxygen in the room.

Note

This wood stove needs periodic inspection and repair for proper operation. It is against federal regulations to operate this wood heater in a manner inconsistent with operating instructions in this manual.

Mobile Home Approved

This Stove is approved for mobile home Installations **when not installed in a sleeping room and when an outside combustion air inlet is provided.**

- The structural integrity of the mobile home floor, ceiling, and walls must be maintained
- The Stove must be properly grounded to the frame of the mobile home with #8 copper ground wire, and use only listed double-wall connector pipe
- Outside Air Kit provided with each Stove must be installed in a mobile home installation and must remain clear of leaves, debris, ice and/or snow. It must be unrestricted while the Stove is in use to prevent room air starvation which causes smoke spillage.
- The Stove must be secured to the mobile home structure by bolting it to the floor through holes provided at bottom of your cast legs on your Stove.

Listings and Certifications



Glass Specifications

This Stove is equipped with 5mm ceramic glass.

Replace glass only with 5mm ceramic glass. Please contact PelPro for replacement glass.

Electrical Rating (On High)

PP70: 120 VAC, 60 Hz, Start 2.6 Amps,

Run 2.3 Amps

BTU & Efficiency Specifications

Model	PP70
Emissions Report No.	0135PS040E
EPA Certified	0.49 grams/hr
*HHV Tested Efficiency	82.8%
**BTU Input	11,676 - 42,535 / hr
***Heating Capacity	750 to 1,450 sq. ft. depending on climate zone
Vent Size	3" or 4" L or PL
Hopper Capacity	130 lbs (Approximate)
Fuel	Wood pellets
Shipping Weight	xxx lbs



This manual describes the installation and operation of the Brand PelPro, Model PP70 wood Stove. This Stove meets the 2020 U.S. Environmental Protection Agency's crib wood emission limits for wood Stoves sold after May 15, 2020. Under specific test conditions this Stove has been shown to deliver heat at rates ranging from 9,603 to 35,278 Btu/hr.

*Weighted average HHV efficiency using data collected during EPA emissions test.

**BTU input/output will vary, depending on the brand of fuel you use in your Stove.

***Heating capacity depends on climate zone, structure layout, insulation, windows, etc.

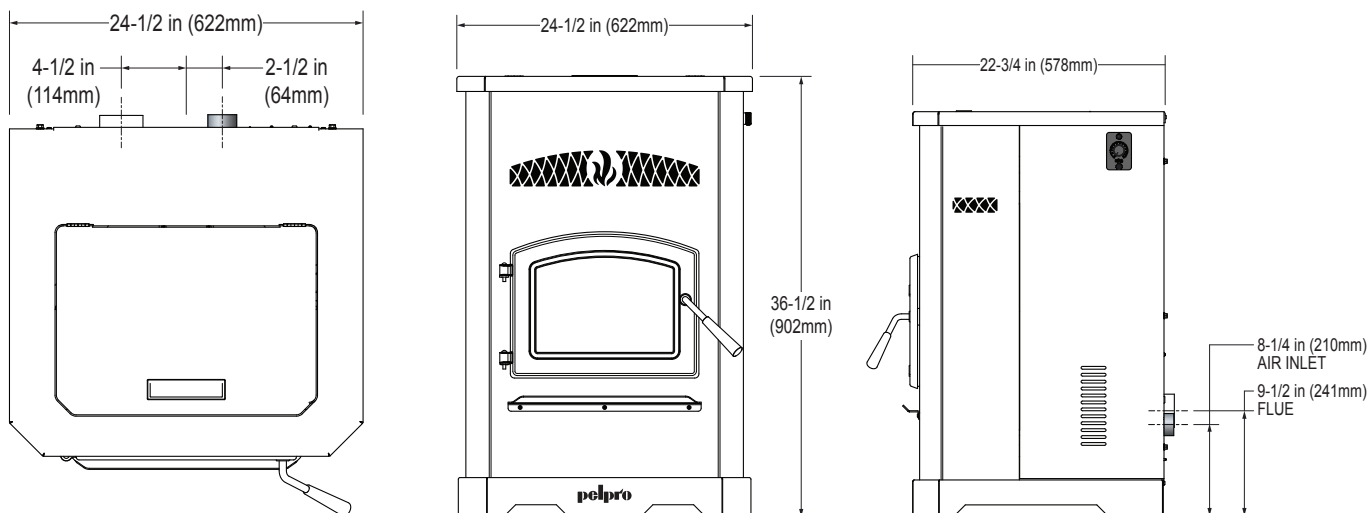

Listings and Certifications



Hearth & Home Technologies, Inc. - PelPro Limited Warranty

Hearth & Home Technologies, Inc. (HHT), on behalf of its PelPro brand, extends the following warranty for PelPro Stoves purchased from an authorized retailer.

If you experience issues with your PelPro Stove, Consumer Care is available to assist you with troubleshooting technical issues. Please contact PelPro Consumer Care at 1-877-427-3316 with any product issues rather than contacting the retailer where you purchased your PelPro Stove.

This warranty covers components of the PelPro Stoves as listed in the table below.

Warranty Coverage:

Subject to the table below, HHT warrants to the owner of the PelPro Stove that the Stove will be free from defects in materials and workmanship at the time of manufacture. After installation, if covered components are found to be defective in materials or workmanship during the applicable warranty period, HHT will replace the covered components.

HHT, at its own discretion, may fully discharge all of its obligations under such warranties by replacing the product itself or refunding the verified purchase price of the product itself. The maximum amount recoverable under this warranty is limited to the purchase price of the product. This warranty is subject to conditions, exclusions, and limitations as described below.

Warranty Period:

Warranty coverage begins on the date of original purchase. The warranty period for covered components is as follows:

Components Covered	Warranty Period (Parts only, Labor not included)
Electrical	1 Year
Steel Parts (excluding fire pot)	5 Years
All replacement parts are covered for remainder of original warranty period or 90 days, whichever is longer	90 Days

Parts Service & Returns:

HHT is proud to offer the best technical and sales support in the industry. If you have any questions about how to operate your Stove or if you need service parts, please visit Pelprostoves.com or call 1-877-427-3316.

Warranty Exclusions:

Warranty does not cover damage or breakage due to misuse, improper handling or modifications. There is no warranty on the paint, glass, fire pot, fire brick, or any gaskets, or against damage caused from corrosion. There is no expressed or implied performance warranty on PelPro Stoves as HHT has no control over the installation, operation, cleaning, maintenance, or type of fuel burned.

Some states do not allow exclusion or limitation of incidental or consequential damages, or limitations of implied warranties, so the limitations or exclusions set forth in this limited warranty may not apply to you. This limited warranty gives you specific legal rights and you may have other rights, which vary from state to state. Warranty is void if the PelPro Stove has not been installed, operated, cleaned and maintained in strict accordance with HHT's instructions.

NEITHER HHT NOR THE RETAILER FROM WHO YOU PURCHASED YOUR PELPRO Stove SHALL BE RESPONSIBLE, LEGALLY OR OTHERWISE, FOR THE INCIDENTAL OR CONSEQUENTIAL DAMAGE TO PROPERTY OR PERSONS RESULTING FROM THE USE OF THIS PRODUCT. ANY WARRANTY IMPLIED BY LAW, INCLUDING BUT NOT LIMITED TO IMPLIED WARRANTIES OF THE MERCHANTABILITY OR FITNESS, SHALL BE LIMITED TO ONE (1) YEAR ON THE BREACH OF THIS WARRANTY OR ANY TYPE OF WARRANTY EXPRESSED OR IMPLIED BY LAW. HHT SHALL IN NO EVENT BE LIABLE FOR ANY SPECIAL, INDIRECT, CONSEQUENTIAL OR OTHER DAMAGES OF ANY NATURE WHATSOEVER IN EXCESS OF THE ORIGINAL PURCHASE PRICE OF THIS PRODUCT. ALL WARRANTIES BY HHT ARE SET FORTH HEREIN AND NO CLAIM SHALL BE MADE AGAINST HHT ON ANY ORAL WARRANTY OR REPRESENTATION.

Reference Materials



Service Parts

Pellet Stove

PP130

Beginning Manufacturing Date: Apr 2014

Ending Manufacturing Date: Active

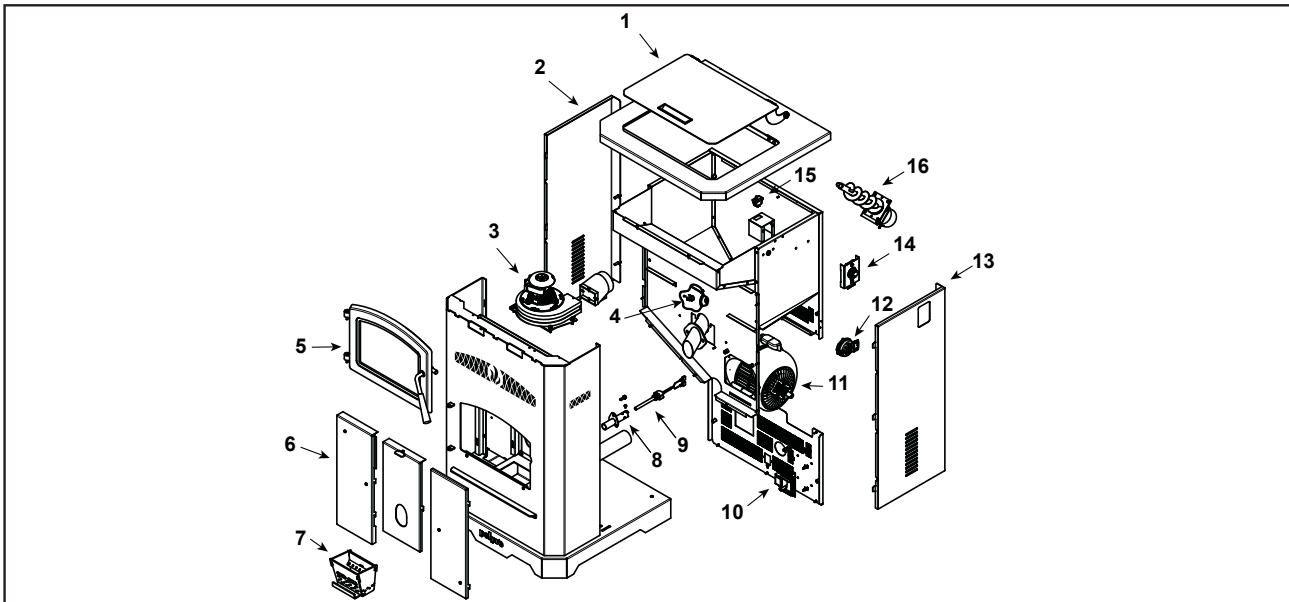

IMPORTANT: THIS IS DATED INFORMATION. When requesting service or replacement parts for your appliance please provide model number and serial number. All parts listed in this manual must be ordered from a dealer.



Stocked at Depot

ITEM	DESCRIPTION	COMMENTS	PART NUMBER	Stocked at Depot
1	Hopper Lid Assembly		SRV7086-019	
	Hopper Extension		PPHE200	
	Handle, Hopper Lid		SRV200-0110	
2	Side Curtain, Left Hand		SRV7086-154	
3	Exhaust Combustion Blower		812-4400	Y
	Gasket, Between Blower Housing and Stove		SRV240-0812	Y
	Gasket, Between Blower Housing and Motor		812-4710	Y
4	Snap disc, Manual Reset		SRV230-0080	Y
5	Door Assembly		SRV7086-021	Y
6	Baffle Kit		SRV7077-006	
7	Firepot		SRV7077-003	Y
8	Igniter Chamber Kit		SRV7077-110	
9	Igniter Kit		SRV7000-660	Y
10	Control Board		SRV7077-050	Y
11	Convection Blower		KS-5020-1052	Y
	Convection Blower Bracket		SRV7081-210	
12	Vacuum Switch		SRV7000-531	Y
	Vacuum Hose, 5/32 ID	3 Ft	SRV240-0450	Y
13	Side Curtain, Right Hand		SRV7086-153	Y
14	Dial Control		SRV7083-036	Y
	Wire Harness, Dial Control		SRV7000-667	Y
15	Hopper Switch		SRV7000-612	Y

See Following page for additional service parts

104 of 110

2/18

Reference Materials



Service Parts

PP130

Beginning Manufacturing Date: Apr 2014
Ending Manufacturing Date: Active

#5 Door Assembly

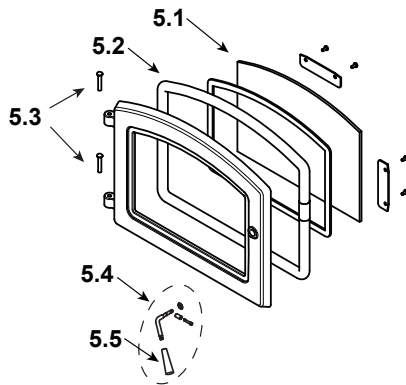

IMPORTANT: THIS IS DATED INFORMATION. When requesting service or replacement parts for your appliance please provide model number and serial number. All parts listed in this manual must be ordered from a dealer.



Stocked at Depot

ITEM	DESCRIPTION	COMMENTS	PART NUMBER	Stocked at Depot
5	Door Assembly		SRV7086-021	Y
5.1	Glass Assembly		SRV7081-173	
5.2	Rope, Door, 3/4" x 84"		832-1680	
5.3	Hinge Pins	Pkg of 2	433-1590/2	
5.4	Threaded Handle Assembly Kit		SRV7093-024	Y
5.5	Handle Black Phenolic Kit		KS-5140-1442	Y

#16 Feed Assembly Kit

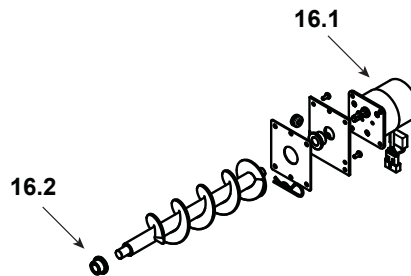

16	Feed Assembly Kit		SRV7077-014	Y
16.1	Feed Motor		SRV7000-670	Y
16.2	Feed Shaft Bushing	Pkg of 2	7000-600/2	Y
	Power Cord		812-1180	Y
	Ambient Probe		SRV7000-668	Y
	Exhaust Probe		SRV7000-669	Y
	Wire Harness		SRV7093-184	Y
	Wire Clip	Pkg of 10	7000-400/10	Y



Hearth & Home Technologies®
352 Mountain House Road
Halifax, PA 17032

10 of 110